

PH METER

PO 650

(OPERATING MANUAL)



TECHNICAL SPECIFICATIONS:

METER	
1. Physical dimensions Panel cut out	105 X 105 X 130 mm 92 mm X 92 mm
2. Enclosure	ABS Weather proof/IP 65
3. Mounting	Field/Panel
4. Parameter sampling rate	< 2 seconds
5. Resolution	0.01
6. Accuracy	± 2% of FSD
7. Power supply	230V A.C./110V A.C./24V D.C.
8. Alarms	Separate LED indication for high & low pH value
9. Control relays	Individual high & low relay (programmable through entire range with settable control delay & hysteresis)
10. Display	4 Digit 7 SEGMENT LED
11. Calibration/Set point	Using front panel keypad.
12. Output	4-20 mA D.C.Current } (Optional) RS-485
13. Range	00.00 to 14.00 pH
SENSOR	
1. Overall dimension	140 mm(L) X 32 mm(W)
2. Type	Flow through/Tank(Optional)
3. Sensor O/P	Milli Volt
4. Electrode material	Glass bulb with epoxy body
5. Process connection	3/4" / 1/2" BSP M
6. Integral cable	1 core shielded 3 meter (STD)
7. Application	Water
8. Temperature	0-60°C/0-100°C with temp. Probe
9. Max. Pressure	Not meant for pressurized line

2

GETTING ACQUAINTED WITH THE METER:

This meter is user friendly & easy to understand. Its operation will be clear when we go through all the parts of the meter.

1. **SENSOR** : It is the main part of the Ph Meter. It has two electrodes : One reference and one measuring electrode enclosed in glass tubing. This is dipped into the line of which Ph is to be measured, it senses the Ph and sends a signal to the meter.
2. **METER** : This is the unit that processes the information received from the sensor and displays the Actual Ph in the line. This unit also controls the Ph by giving signals to dosing pumps, hooters, valves etc through inbuilt relays.

WIRING CONNECTIONS:

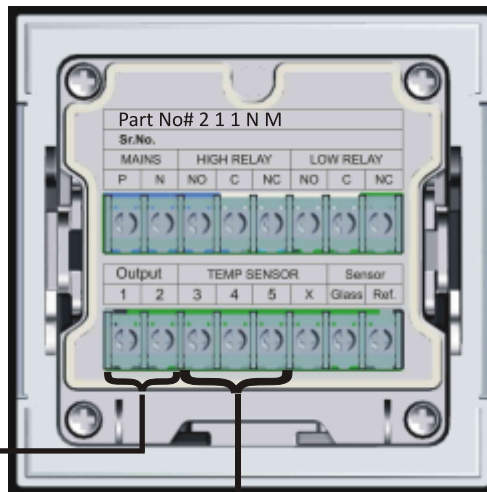

Description	Terminal details	3	4	5
Without Temperature sensor	Not appl.	X	X	X
With Temperature sensor	Temp.Sensor	W	W	R

Part no.	Description	Terminal details	1	2
PO-650 2 1 N	With relay output only	Not appl.	X	X
PO-650 2 1 C	4-20 mA current O/P with relays	Current O/P	+	-
PO-650 2 1 R	RS-485 O/P with relays	RS 485 O/P(Tx)	+	-

INSTALLATION GUIDELINES:

SENSOR:

- The PH sensor is normally supplied with 3/4" installation fitting with female threading.
- The sensor should be mounted **vertically** in the line.
- The sensor shall be connected in the sampling line only as the sensor body is not meant for the pressurized line.
- The fitting can be connected to the sampling point by flexible tubing.

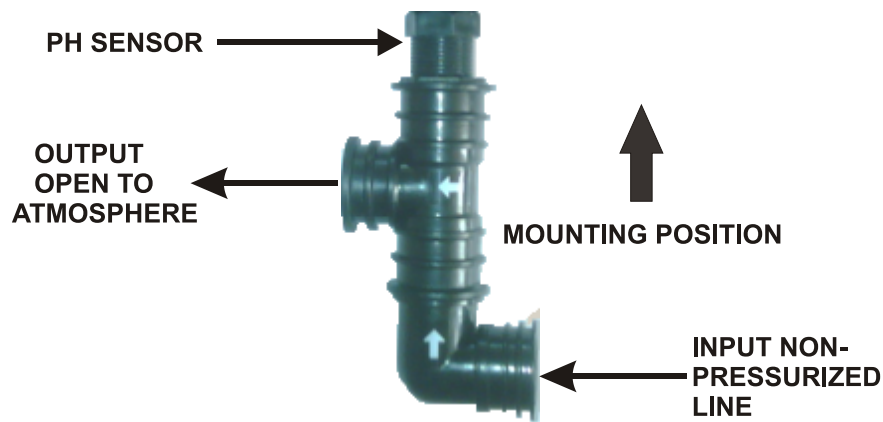

METER:

The meter is designed to suit field, panel as well as sensor mounting as shown below.

MOUNTING POSSIBILITIES

PANEL MOUNT APPLICATION

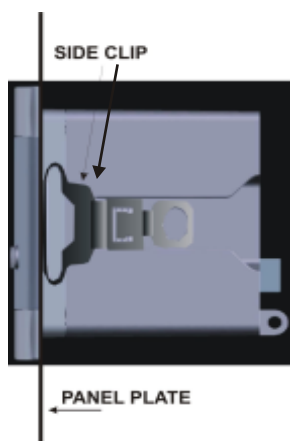

Press this downwards
& Push forward to lock

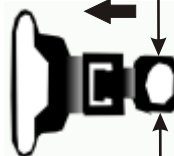

Press this downwards
& Pull out to unlock.



SENSOR MOUNT APPLICATION



METER OPERATION:

In regular operation, the Ph Meter displays the actual Ph in the Line. Pressing the view key will display all the settings in the Ph meter.

PROGRAMMING THE SET POINT:

For programming the set points follow the guideline below:

KEY TO BE PRESSED	DISPLAY
MENU	St Hi (Set High)
MENU	Previously set high Ph value
Use ACK. & VIEW key to set required high Ph value	
MENU	HYS1(Hysteresis* 1)
MENU	Previously set Hysteresis value
Use ACK. & VIEW key to set required Hysteresis value	
MENU	St Lo(Set Low)
MENU	Previously set low Ph value
Use ACK. & VIEW key to set required Low Ph value	
MENU	HYS2(Hysteresis* 2)
MENU	Previously set Hysteresis value
Use ACK. & VIEW key to set required hysteresis value	
MENU	TEmp(Temperature)
MENU	Previously set temp. value
Use ack. & view key to set temp value	
MENU	End

***Hysteresis:**

The %age value for which the relay will not reset after getting energised. For eg. If the high Ph value is set at 9.00 and the hysteresis is kept at 10% then the high relay will get energised the moment pH exceeds 9.0 (after the set control delay) and will remain energized until the Ph value falls to 8.1..And similar is the case with hyst2 i.e. for low Ph.If low set point is 5 with 10% hysteresis, the relay gets reset only when the pH goes over 5.5. (Normally, both hysteresis values are kept at 10%).

Low set point should be lower than the high set point else meter will show Serr (Set Error).

ON SITE CALIBRATION OF METER:

The PH Meter supplied comes duly calibrated by experienced professionals from our factory. In case the need arises for onsite calibration please follow the below procedure:

Before starting the calibration procedure ensure availability of fresh buffer solutions of 7.00 and 4.00 pH.

KEY TO BE PRESSED	DISPLAY
VIEW & ACK SIMULTANEOUSLY	PASS then 0000
ENTER PASSWORD 0123 USING VIEW & ACK. KEY	
MENU	Calb
MENU	ZERO
Dip the sensor in 7 Ph solution, wait till reading stabilizes	
MENU	Acrd & then reading
ACK	SEtC
& then display will start showing reading (e.g.06.95) with first digit blinking.Set this value to 7.00 using VIEW & ACK. key	
MENU	SPAN
Dip the sensor in 4 Ph solution, wait till reading stabilizes	
MENU	Acrd
ACK	SETC
& then display will start showing reading (e.g.04.05) with first digit blinking. Set this value to 4.00 using VIEW & ACK. key	
MENU 2 times	END

The meter has a two-point setting and a third point checking facility. Dip the sensor in the solution having Ph 9.20; the reading stabilizes between $\pm 2\%$ on both sides of the actual Ph.

Note : In case the actual reading for zero and span differ by 40% then the meter will show Sensor error and start showing readings as per previous calibration.

OPERATION MODES

The meter can be operated in three modes (based on relay operation):

1. **CONTROL MODE:** In this mode, the relay gets energized and will be time proportionately energized between the set value and the hysteresis.e.g.If the high value is kept at 8.00 with 10% hysteresis , between the pH values of 8 & 8.8 high relay would operate in an ON/OFF cycle(total cycle time 10 seconds).

6

The ON time increases as the pH value approaches 8.8 beyond which relay remains energized. The same operation will be for Low Ph value.

2. **ALARM MODE:** In this there are two options:
 - i) AcK (Acknowledge) : In this mode, the relay will get energized and reset once Ack. key is pressed.
 - ii) nAcK (No Acknowledge) : In this mode relay will be energized as long as pH value is across the set point. One can't reset the relay with Ack. Key
3. **AUTO RESET MODE:** In this mode, the relay gets automatically reset after 2 seconds.

KEY TO BE PRESSED	DISPLAY
VIEW & ACK.Simultaneously	PASS
ENTER PASSWORD 0234 USING ACK. & VIEW KEY	
MENU	Cdly (control delay)*
What is this ? This is the delay for which processor will ignore increase/decrease in pH value & will energise relay after this much time (in seconds).	
MENU	0010
Use ACK. & VIEW key to change this time	
MENU	rlop
Use ack. key to make it AUtr(Auto reset) or CntL(Control)	
MENU	Ack
Use ACK. key to make it nAck	
MENU	END
MENU	Actual reading

TYPICAL WIRING DIAGRAM OF A DOSING PUMP THROUGH RELAY :

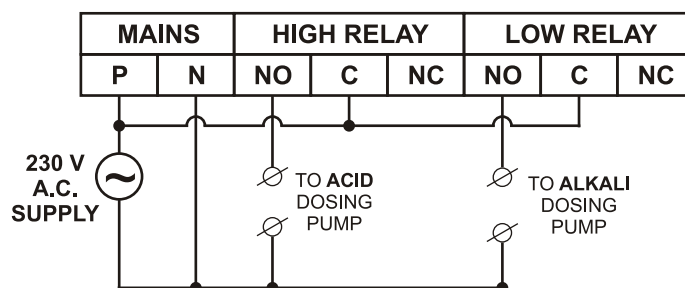

Not Appl.						Sensor	
X	X	X	X	X	X	Glass	Ref.

IN CASE OF 4-20mA OUTPUT:

In case of field transmitter, the meter takes the sensor input & gives 4-20mA output current. The factory settings for ZERO(value of pH at which transmitter would give 4 mA current) & SPAN (value of pH at which transmitter would give 20 mA current) are:

Reading(pH)	Current Output(mA)
00.00	4mA
14.00	20mA

To change the Zero & Span settings follow the guideline below:

KEY TO BE PRESSED	DISPLAY
VIEW & ACK	PASS
ENTER THE PASSWORD 0678 USING VIEW & ACK. KEY	
MENU	Type
MENU	Norm
What is this ? Normally pH gives 4 mA @ ZERO value and 20 mA @ SPAN value , in some cases one might require 4 mA @ SPAN and 20 mA @ ZERO value. In that case make this as inV (Inverse) with ACK key.	
MENU	Zero
MENU	Previously set ZERO value
Use VIEW & ACK.key to change the value	
MENU	SPAN
MENU	Previously set SPAN value
Use VIEW & ACK.key to change the value	
MENU	END

Instrument also works as 4_20 mA current simulator.It gives 4 mA & 20 mA current for the calibration of other instruments.Follow the below guideline:

KEY TO BE PRESSED	DISPLAY
VIEW & ACK	PASS
ENTER THE PASSWORD 0420 USING VIEW & ACK. KEY	
MENU	4 mA
Instrument will give 4 mA current	

8

MENU	20 mA
Instrument will give 20 mA current	
MENU	End
MENU	Actual reading

IN CASE OF RS-485 OUTPUT:

In case of pH meter with RS-485 output, if number of instruments are connected through same wire (as shown below) then each instrument should have its specific address (called as meter address). To set the meter address follow the below guideline.

KEY TO BE PRESSED	DISPLAY
VIEW & ACK Simultaneously	PASS then 0000
ENTER THE PASSWORD 0345 USING VIEW & ACK. KEY	
MENU	bd.rt (Baud Rate)
MENU	4800
Use ACK. Key to make it 9600.	
MENU	Addr(Address)
MENU	Previously set meter address
Use VIEW & ACK.key to change the address.	
MENU	E.nd
MENU	Actual value

Connection diagram for number of meters (with Rs485 O/P) to Computer:

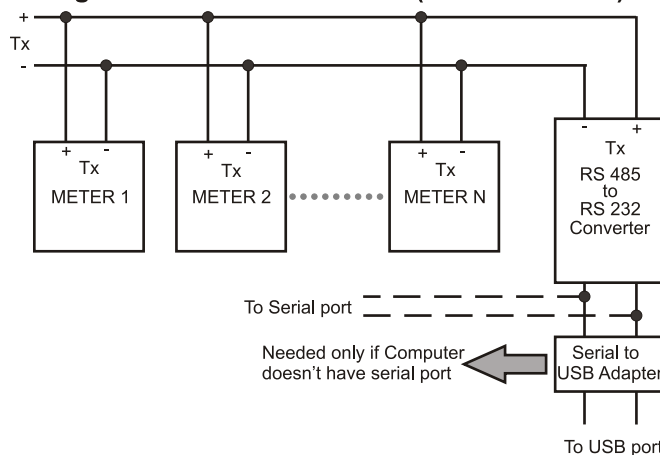

TROUBLESHOOTING:

TROUBLE	PROBABLE CAUSE	ACTION
<u>DURING COMMISSIONING</u>		
Fluctuating readings	Sensor not dipped in the line properly	Loop the outlet tubing such that the tee always remains flooded with water
	Wrong wiring	Connect the wires as per drawing
	Sensor not sensing	Disconnect the sensor, by removing the wires then by shorting the sensor terminals, check the reading ,if at 0 mV the reading is around 7.00, then change the sensor.
<u>DURING CALIBRATION</u>		
Meter shows sensor error	Difference between actual reading of span and zero is less than 40%	Recalibrate the meter
<u>DURING NORMAL SERVICE</u>		
Display Shows Erroneous reading	Sensor not dipped in the line properly	Loop the outlet tubing such that the tee always remains flooded with water
	Sensor output is different than required	Check mV (sensor O/P) by pressing Ack. Key. If it is around 00.00 in 7.00 pH solution recalibrate meter, else change the sensor
Meter shows sensor error	Sensor output may be more or less than the min. or max. values	Recalibrate the meter. If problem persists change the sensor
No display	High voltage	Check MOV/FUSE, if it is burnt then replace it with new one
Frequent Fuse failure	MOV short	Replace MOV* as well as FUSE**

*MOV 14mm Dia. and 320V AC

** FUSE -- 500mA

10

Follow the guideline below for better results.:

DOS	DON'TS
Do remove electrode sleeve or cap before using a new electrode.	Do not touch the bottom part of pH electrode with your hands, especially the bulb or reference junction.
Do keep the cap for long term storage of the pH electrode.	Do not scratch or damage the pH electrode bulb. This may totally break electrode or result in erroneous readings
Do store pH electrode in a soaking solution (pH 4.00 buffer).	Do not use reference electrode with fast flowing reference junction in small samples where flow of reference solution could contaminate the sample.
Do turn pH meter OFF before disconnecting electrode.	Do not mount the sensor in any housing other than the supplied one
Do rinse the pH electrode thoroughly with deionized water before measuring a new sample.	Do not put the sensor in pressurized line. Ensure the output is always kept open to atmosphere.
Do standardize your pH sensor frequently for the most accurate results.	Do not mount sensor in horizontal plane.
	Do not extend sensor cable.