

Vertical multistage centrifugal pumps
50 Hz

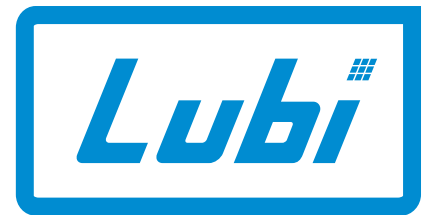

PUMPS • MOTORS

ISO 9001 Company



Pumping Solution





Photographs of a few Manufacturing Units



FILTRA CONSULTANTS AND ENGINEERS LTD.

Gala No. 2 & 3, Ground Floor, Neminath Industrial Estate No. 2, Navghar, Vasai (East), Dist.: Palghar - 401 219
 Tel.: +91 8691009127/26 Email: filtraw@gmail.com Website: www.ewatertreatmentindia.com



Declaration of Conformity

We, **Lubi** hereby declare under our sole responsibility that the products **LCR, LCRI** and **LCRN** to which this declaration relates, are in conformity with these Council Directives on the approximation of the laws of the EC Member States:

- Machinery Directive (2006/42/EC).
Standard used: EN 809: 2009.
- Electromagnetic compatibility (2004/108/EC).
Standards used: EN 61000-6-2 and EN 61000-6-3.

Nosotros, **Lubi** declaramos bajo nuestra entera responsabilidad que los productos **LCR, LCRI** y **LCRN**, a los cuales se refiere esta declaración, están conformes con las Directivas del Consejo en la aproximación de las leyes de los Estados Miembros del EM:

- Directiva de Maquinaria (2006/42/CE).
Normas aplicada: EN 809: 2009.
- Compatibilidad electromagnética (2004/108/CE).
Normas aplicadas: EN 61000-6-2 y EN 61000-6-3.

Nous, **Lubi** déclarons sous notre seule responsabilité, que les produits **LCR, LCRI** et **LCRN**, auxquels se réfère cette déclaration, sont conformes aux Directives du Conseil concernant le rapprochement des législations des Etats membres CE relatives aux normes énoncées cidessous:

- Directive Machines (2006/42/CE).
Norme utilisées: EN 809: 2009.
- Compatibilité électromagnétique (2004/108/CE).
Normes utilisées: EN 61000-6-2 et EN 61000-6-3.

J.J. Amin

Technical Director



Selection and sizing

Vertical multistage centrifugal pumps

Selection of pumps

Selection of pumps should be based on:

- The duty point of pump (see section A)
- Dimensional data such as pressure loss as a result of height differences, friction loss in the pipework, pump efficiency etc. (see section B)
- Pump materials (see section C)
- Pump connections (see section D)
- Shaft seal (see section E)

A. Duty point of the pump

From a duty point it is possible to select a pump on the basis of the curve charts shown in "Performance curves" from page 23.

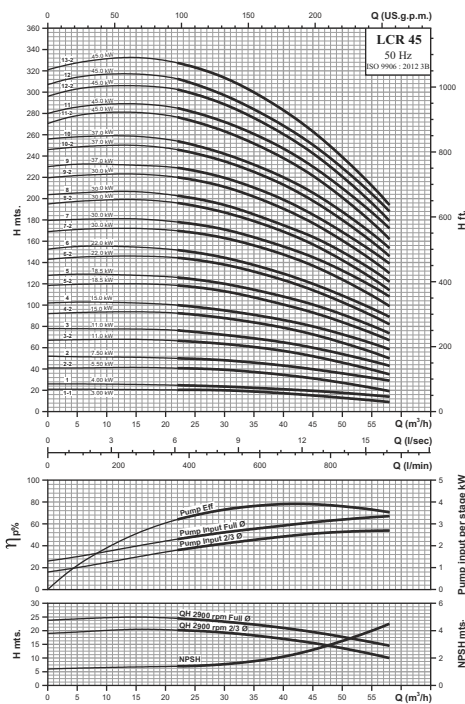

Fig. 6 Example of curve chart

B. Dimensional data

When sizing a pump, take the following factors into account:

- Required flow and pressure at the pump delivery point.
 - Pressure loss as a result of height differences (H_s).
 - Friction loss in the pipe work (H_f).
- It may be necessary to account for pressure loss in connection with long pipes, bends or valves, etc.
- Best efficiency at the estimated duty point.
 - NPSH value.

For calculation of the NPSH value see "Minimum inlet pressure - NPSH", page 18.

LCR, LCRI, LCRN

Pump efficiency

Before determining the best efficiency point, the operation pattern of the pump needs to be identified.

Is the pump expected to operate at the **same** duty point, then select a LCR pump which is operating at a duty point corresponding with the best efficiency of the pump.

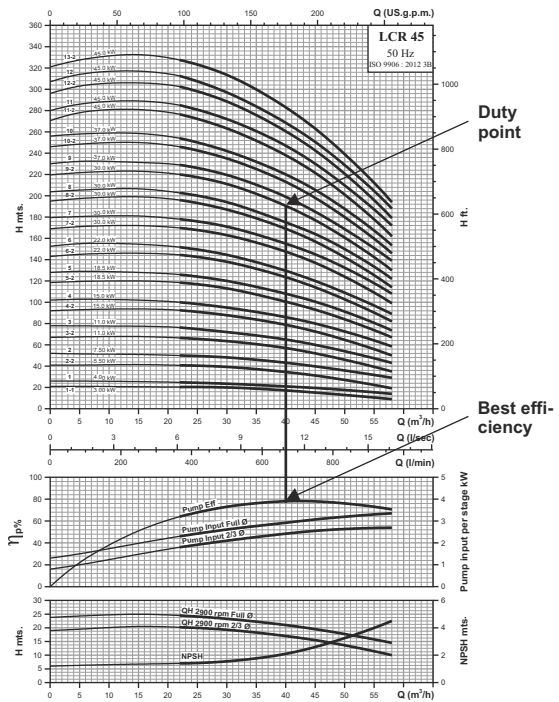

Fig. 7 Example of LCR pump's duty point

As the pump is sized on the basis of highest possible flow, it is important always to have the duty point to the right on the efficiency curve (η) in order to keep efficiency high when the flow drops.

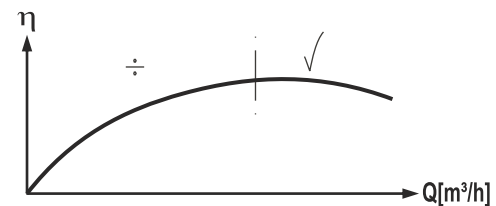

Fig. 8 Best efficiency

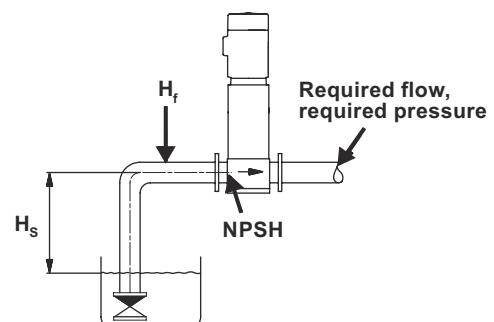

Fig. 9 Dimensional data

Selection and sizing

Vertical multistage centrifugal pumps

C. Pump material

The material variant (LCR, LCRI, LCRN) should be selected based on the liquid to be pumped. The product range covers the following three basic types.

- The LCR, LCRI pump types are suitable for clean, non-aggressive liquids such as potable water, oils etc.
- The LCRN pump type is suitable for industrial liquids and acids.

D. Pump connections

Selection of pump connection depends on the rated pressure and pipework. To meet any requirement the LCR, LCRI and LCRN pumps offer a wide range of flexible connection such as:

- DIN flange (for LCR, LCRI, LCRN 1s, 1, 2, 3, 4, 5, 10, 15, 20, 32, 45, 64, 90, 120, 150)
- Other connection on request

E. Shaft seal

As standard, the LCR range is fitted with a Lubi shaft seal suitable for the most common applications.

The following key parameters **must** be taken into account, when selecting the shaft seal:

- Type of pumped liquid
- Liquid temperature and
- Maximum pressure.

Lubi offers a wide range of shaft seal variants to meet specific demands.

Inlet pressure and operating pressure

The limit values stated on page 14 and page 15 must **not** be exceeded as regards....

- Maximum inlet pressure and
- Maximum operating pressure.

LCR, LCRI, LCRN

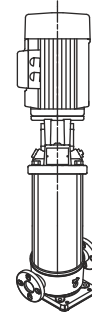

Fig. 10 LCR pump

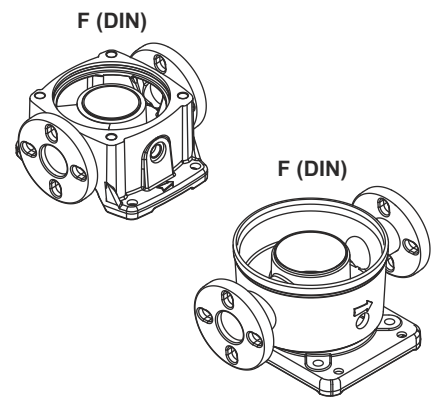

Fig. 11 Pump connections

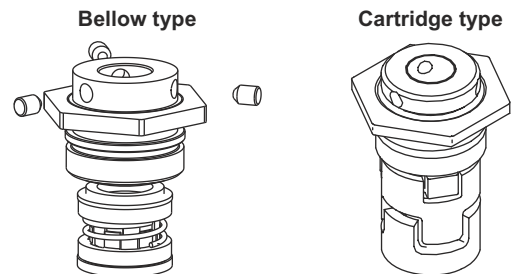

Fig. 12 Shaft seal

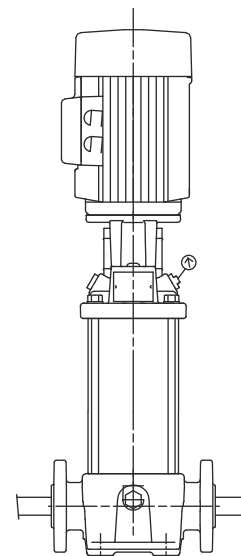

Fig. 13 Inlet and operating pressure

Selection and sizing

LCR, LCRI, LCRN

Vertical multistage centrifugal pumps

Minimum inlet pressure – NPSH

Calculation of the inlet pressure “H” is recommended when....

- The liquid temperature is high,
- The flow is significantly higher than the rated flow,
- Water is drawn from depths,
- Water is drawn through long pipes,
- Inlet conditions are poor.

To avoid cavitation, make sure that there is a minimum pressure on the suction side of the pump. The maximum suction lift “H” in metres head can be calculated as follows.

$$H = p_b \times 10.2 - \text{NPSH} - H_f - H_v - H_s$$

p_b = Barometric pressure in bar.
(Barometric pressure can be set to 1 bar).
In closed systems, p_b indicates the system pressure in bar.

NPSH = Net Positive Suction Head in metres head.
(To be read from the NPSH curve at the highest flow the pump will be delivering).

H_f = Friction loss in suction pipe in metres head.
(At the highest flow the pump will be delivering).

H_v = Vapour pressure in metres head.
(To be read from the vapour pressure scale.
“ H_v ” depends on the liquid temperature “ T_m ”).

H_s = Safety margin = minimum 0.5 metres head.

If the “H” calculated is positive, the pump can operate at a suction lift of maximum “H” metres head.

If the “H” calculated is negative, an inlet pressure of minimum “H” metres head is required.

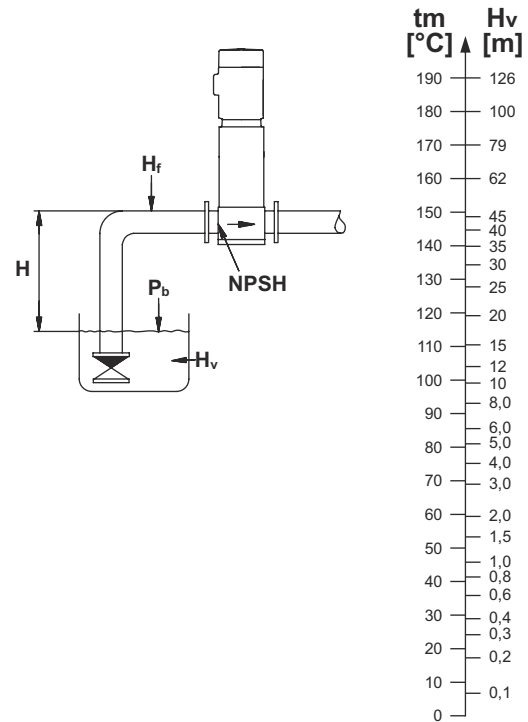

Fig. 14 Minimum inlet pressure - NPSH

Note: In order to avoid cavitation **never** select a pump with a duty point too far to the right on the NPSH curve.

Always check, the NPSH value of the pump at the highest possible flow.

Selection and sizing

Vertical multistage centrifugal pumps

How to read the curve charts

LCR, LCRI, LCRN

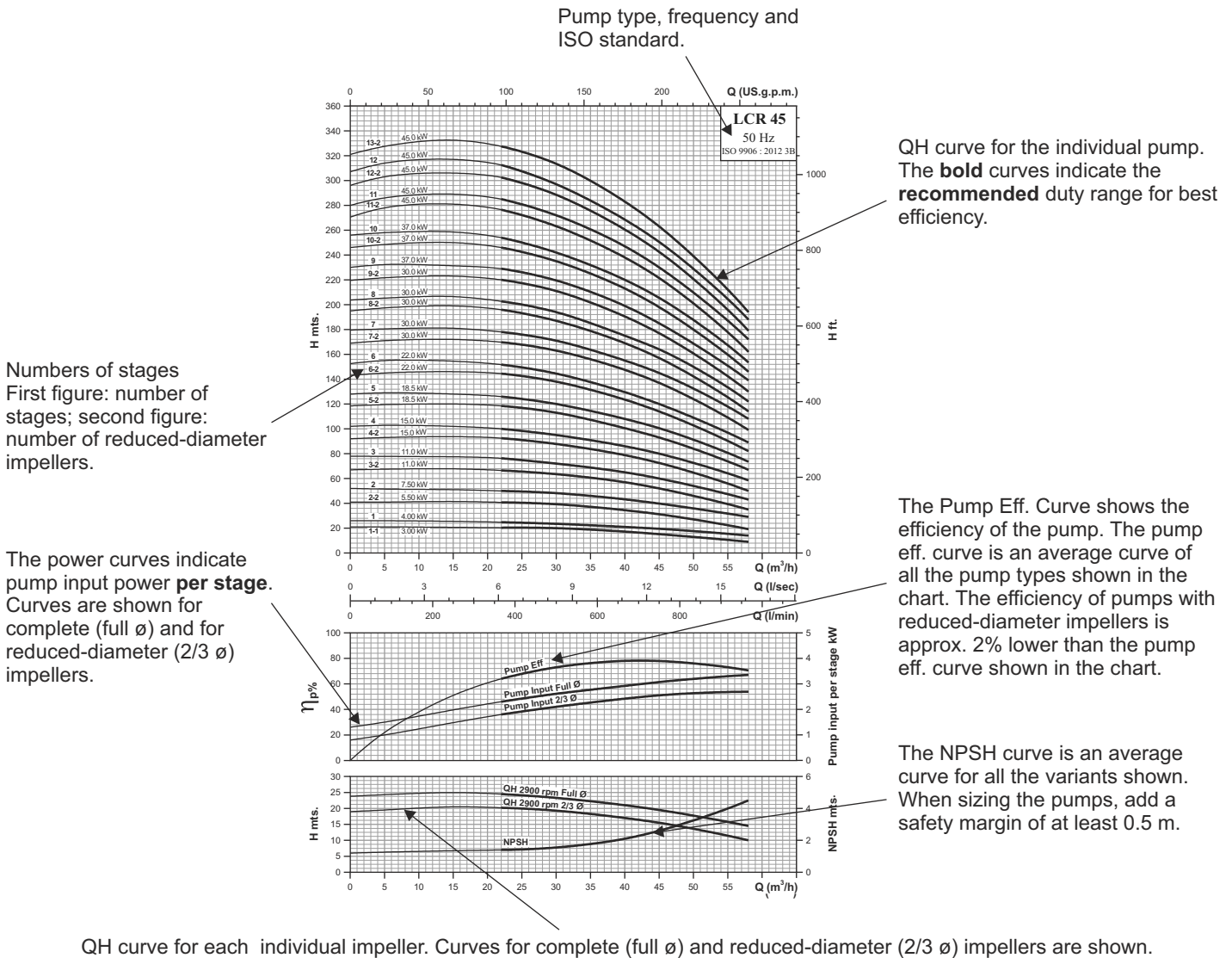

Fig. 15 How to read the curve charts

Guidelines to performance curves

The guidelines below apply to the curves shown on the following pages:

- Tolerances to ISO 9906, Annex A, if indicated.
- The motors used for the measurements are standard motors.
- Measurements have been made with airless water at a temperature of 20° C.
- The curves apply to a kinematic viscosity of $\nu = 1 \text{ mm}^2/\text{s}$ (1 cSt).
- Due to the risk of overheating, the pumps should not be used at a flow below the minimum flow rate.
- The QH curves apply to a rated motor speed of 2900 min^{-1} . All curves are based on current motor speeds.

The curve below shows the minimum flow rate as a percentage of the nominal flow rate in relation to the liquid temperature.

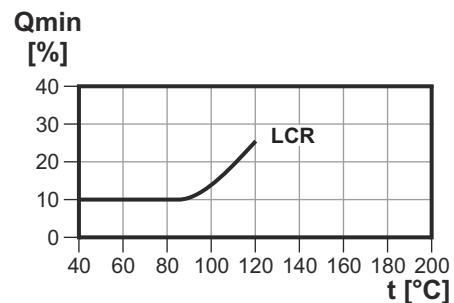

Fig. 16 Minimum flow rate

Pumped liquids

LCR, LCRI, LCRN

Vertical multistage centrifugal pumps

Pumped liquids

Thin non-explosive liquids and not containing solid particles or fibers are suitable. The liquid must also not chemically attack the pump materials.

When pumping liquids with a density and/or viscosity higher than that of water, oversized motors must be used, if required.

Whether a pump is suitable for a particular liquid depends on a number of factors of which the most important are the chloride content, pH value, temperature and content of chemicals, oils etc.

Please note that aggressive liquids (e.g. sea water and some acids) may attack or dissolve the protective oxide film of the stainless steel and thus cause corrosion.

The LCR, LCRI, LCRN pump types are suitable for the following liquids.

LCR, LCRI

- Non-corrosive liquids.
- For liquid transfer, circulation and pressure boosting of cold or hot clean water.

LCRN

- Industrial liquids.

In systems where all parts in contact with the liquid must be made of high-grade stainless steel.

Motor Data

LCR, LCRI, LCRN

Vertical multistage centrifugal pumps

Standard motor for LCR, LCRI, LCRN 50 Hz

Type	Motor H.P	Motor kW	Phase	Frame size	Standard voltage [V]	I _{1/1} [A]	Cos Ø _{1/1}	η[%]	I _{start}
MCR500052211	0.50	0.37	1	71	220-240*	2.6/2.4	0.98	62.0	13/12
MCR500072211	0.75	0.55	1	71	220-240*	4.6/4.5	0.98	64.0	23/22
MCR500102211	1.00	0.75	1	80	220-240*	5.1/4.8	0.97	68.0	28/26
MCR500152211	1.50	1.10	1	80	220-240*	6.85/6.7	0.97	73.0	36.5/35
MCR500202211	2.00	1.50	1	90	220-240*	9.1/8.3	0.98	76.0	46/42
MCR500302211	3.00	2.20	1	90	220-240*	12.5/11.7	0.98	80.0	63/59
MCR500058231	0.50	0.37	3	71	220-240Δ/(380-415Y*)	1.46/0.85	0.87	70.0	7.3/4.3
MCR500078231	0.75	0.55	3	71	220-240Δ/(380-415Y*)	2.2/1.5	0.91	70.0	11/7.5
MCR500108231	1.00	0.75	3	80	220-240Δ/(380-415Y*)	2.6/1.6	0.90	77.0	15.6/9.6
MCR500158231	1.50	1.10	3	80	220-240Δ/(380-415Y*)	3.9/2.3	0.90	76.2	23.4/13.8
MCR500208231	2.00	1.50	3	90	220-240Δ/(380-415Y*)	5.1/3.0	0.91	78.5	30.6/18
MCR500308231	3.00	2.20	3	90	220-240Δ/(380-415Y*)	7.6/4.5	0.89	81.0	45.6/27
MCR500408231	4.00	3.00	3	100	220-240Δ/(380-415Y*)	9.9/5.8	0.88	83.0	59.4/34.8
MCR500558231	5.50	4.00	3	112	220-240Δ/(380-415Y*)	13.9/8.1	0.82	84.0	83.4/48.6
MCR500754231	7.50	5.50	3	132	380-415Δ*	11.2/10.6	0.91	85.7	67.2/63.6
MCR501004231	10.0	7.50	3	132	380-415Δ*	14.8/14.5	0.82	87.0	96.2/94.3
MCR501504231	15.0	11.0	3	160	380-415Δ*	20.8/19.0	0.89	90.5	135.2/123.5
MCR502004231	20.0	15.0	3	160	380-415Δ*	28.5/26	0.88	91.0	185.3/169
MCR502504231	25.0	18.5	3	160	380-415Δ*	35/32	0.88	92.0	245/224
MCR503004231	30.0	22.0	3	180	380-415Δ*	44/40	0.83	92.0	308/280
MCR504004231	40.0	30.0	3	200	380-415Δ*	54.5/50	0.90	93.0	381/350
MCR505004231	50.0	37.0	3	200	380-415Δ*	67/61	0.90	93.0	469/427
MCR506004231	60.0	45.0	3	225	380-415Δ*	78/71	0.94	93.5	546/497
MCR507504231	75.0	55.0	3	250	380-415Δ*	95/88	0.93	93.5	665/616
MCR510004231	100.0	75.0	3	280	380-415Δ*	135/123	0.90	94.0	945/861

- (*) Standard voltage

- Special voltages available on request.