

Technical Data

Vertical multistage centrifugal pumps

LCR 32

Performance Chart

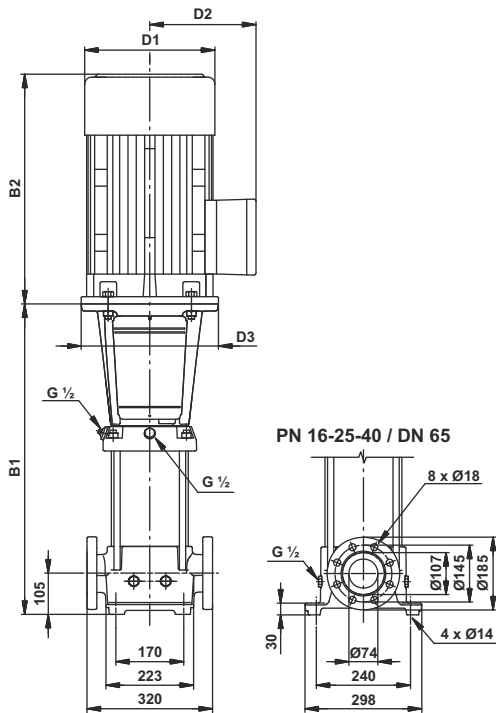

| Pump Type | H.P. | kW | Q l/min m ³ /h | n = 2900 rpm | | | | | |
|-------------|------|------|---------------------------------|--------------|-------|-------|-------|-------|-------|
| | | | | 250.0 | 333.3 | 400.0 | 466.7 | 533.3 | 600.0 |
| | | | | 15.0 | 20.0 | 24.0 | 28.0 | 32.0 | 36.0 |
| LCR 32/1-1 | 2.00 | 1.50 | H mts. | 16 | 15 | 13 | 12 | 10 | 8 |
| LCR 32/1 | 3.00 | 2.20 | | 19 | 18 | 16 | 15 | 13 | 11 |
| LCR 32/2-2 | 4.00 | 3.00 | | 31 | 29 | 26 | 24 | 21 | 17 |
| LCR 32/2 | 5.50 | 4.00 | | 38 | 35 | 33 | 31 | 27 | 23 |
| LCR 32/3-2 | 7.50 | 5.50 | | 51 | 48 | 44 | 41 | 36 | 30 |
| LCR 32/3 | 7.50 | 5.50 | | 57 | 54 | 51 | 47 | 42 | 36 |
| LCR 32/4-2 | 10.0 | 7.50 | | 69 | 66 | 61 | 56 | 50 | 42 |
| LCR 32/4 | 10.0 | 7.50 | | 76 | 72 | 68 | 63 | 56 | 49 |
| LCR 32/5-2 | 15.0 | 11.0 | | 89 | 85 | 80 | 74 | 66 | 56 |
| LCR 32/5 | 15.0 | 11.0 | | 96 | 91 | 85 | 79 | 72 | 63 |
| LCR 32/6-2 | 15.0 | 11.0 | | 107 | 102 | 96 | 89 | 79 | 69 |
| LCR 32/6 | 15.0 | 11.0 | | 114 | 109 | 103 | 96 | 86 | 76 |
| LCR 32/7-2 | 20.0 | 15.0 | | 127 | 120 | 113 | 105 | 94 | 82 |
| LCR 32/7 | 20.0 | 15.0 | | 133 | 127 | 120 | 112 | 102 | 90 |
| LCR 32/8-2 | 20.0 | 15.0 | | 146 | 138 | 130 | 120 | 108 | 94 |
| LCR 32/8 | 20.0 | 15.0 | | 151 | 143 | 135 | 126 | 113 | 100 |
| LCR 32/9-2 | 25.0 | 18.5 | | 165 | 157 | 148 | 137 | 123 | 108 |
| LCR 32/9 | 25.0 | 18.5 | | 172 | 163 | 153 | 143 | 130 | 115 |
| LCR 32/10-2 | 25.0 | 18.5 | | 184 | 175 | 165 | 153 | 137 | 120 |
| LCR 32/10 | 25.0 | 18.5 | | 191 | 182 | 171 | 159 | 144 | 127 |
| LCR 32/11-2 | 30.0 | 22.0 | 204 | 194 | 183 | 170 | 153 | 134 | |
| LCR 32/11 | 30.0 | 22.0 | 210 | 200 | 188 | 176 | 159 | 141 | |
| LCR 32/12-2 | 30.0 | 22.0 | 223 | 212 | 200 | 187 | 168 | 148 | |
| LCR 32/12 | 30.0 | 22.0 | 229 | 217 | 206 | 193 | 176 | 155 | |
| LCR 32/13-2 | 40.0 | 30.0 | 244 | 233 | 221 | 208 | 188 | 167 | |
| LCR 32/13 | 40.0 | 30.0 | 250 | 239 | 227 | 213 | 194 | 172 | |
| LCR 32/14-2 | 40.0 | 30.0 | 263 | 251 | 237 | 221 | 200 | 177 | |
| LCR 32/14 | 40.0 | 30.0 | 270 | 257 | 244 | 228 | 208 | 184 | |

Dimensions & Weights of LCR Pump

| Pump type | Dimensions [mm] | | | | | Net weight [kg] | Gross weight [kg] | Gross volume [m ³] |
|-------------|-----------------|-------|-----|-----|-----|-----------------|-------------------|--------------------------------|
| | DIN flange | | D1 | D2 | D3 | | | |
| | B1 | B1+B2 | | | | | | |
| LCR 32/1-1 | 505 | 783 | 165 | 130 | 135 | 61.0 | 119.0 | 0.3745 |
| LCR 32/1 | 505 | 783 | 165 | 130 | 135 | 62.0 | 120.0 | 0.3745 |
| LCR 32/2-2 | 575 | 879 | 194 | 140 | - | 76.0 | 134.0 | 0.3745 |
| LCR 32/2 | 575 | 925 | 220 | 150 | 158 | 87.0 | 145.0 | 0.3745 |
| LCR 32/3-2 | 645 | 1055 | 262 | 177 | 298 | 107.0 | 165.0 | 0.3745 |
| LCR 32/3 | 645 | 1055 | 262 | 177 | 298 | 107.0 | 165.0 | 0.3745 |
| LCR 32/4-2 | 715 | 1125 | 262 | 177 | 298 | 117.0 | 175.0 | 0.3745 |
| LCR 32/4 | 715 | 1125 | 262 | 177 | 298 | 117.0 | 175.0 | 0.3745 |
| LCR 32/5-2 | 895 | 1437 | 304 | 225 | 350 | 155.0 | 225.0 | 0.4495 |
| LCR 32/5 | 895 | 1437 | 304 | 225 | 350 | 155.0 | 225.0 | 0.4495 |
| LCR 32/6-2 | 965 | 1507 | 304 | 225 | 350 | 158.0 | 228.0 | 0.4495 |
| LCR 32/6 | 965 | 1507 | 304 | 225 | 350 | 158.0 | 228.0 | 0.4495 |
| LCR 32/7-2 | 1035 | 1577 | 304 | 225 | 350 | 175.0 | 245.0 | 0.4495 |
| LCR 32/7 | 1035 | 1577 | 304 | 225 | 350 | 175.0 | 245.0 | 0.4495 |
| LCR 32/8-2 | 1105 | 1647 | 304 | 225 | 350 | 178.0 | 248.0 | 0.4495 |
| LCR 32/8 | 1105 | 1647 | 304 | 225 | 350 | 178.0 | 248.0 | 0.4495 |
| LCR 32/9-2 | 1175 | 1717 | 304 | 225 | 350 | 211.0 | 294.0 | 0.5370 |
| LCR 32/9 | 1175 | 1717 | 304 | 225 | 350 | 211.0 | 294.0 | 0.5370 |
| LCR 32/10-2 | 1245 | 1787 | 304 | 225 | 350 | 214.0 | 297.0 | 0.5370 |
| LCR 32/10 | 1245 | 1787 | 304 | 225 | 350 | 214.0 | 297.0 | 0.5370 |
| LCR 32/11-2 | 1315 | 1925 | 363 | 262 | 350 | 250.0 | 333.0 | 0.5370 |
| LCR 32/11 | 1315 | 1925 | 363 | 262 | 350 | 250.0 | 333.0 | 0.5370 |
| LCR 32/12-2 | 1385 | 1995 | 363 | 262 | 350 | 254.0 | 337.0 | 0.5370 |
| LCR 32/12 | 1385 | 1995 | 363 | 262 | 350 | 254.0 | 337.0 | 0.5370 |
| LCR 32/13-2 | 1455 | 2101 | 415 | 300 | 400 | 322.0 | 419.0 | 0.6245 |
| LCR 32/13 | 1455 | 2101 | 415 | 300 | 400 | 322.0 | 419.0 | 0.6245 |
| LCR 32/14-2 | 1525 | 2171 | 415 | 300 | 400 | 325.0 | 422.0 | 0.6245 |
| LCR 32/14 | 1525 | 2171 | 415 | 300 | 400 | 325.0 | 422.0 | 0.6245 |

Performance Curves

Vertical multistage centrifugal pumps

LCR 32

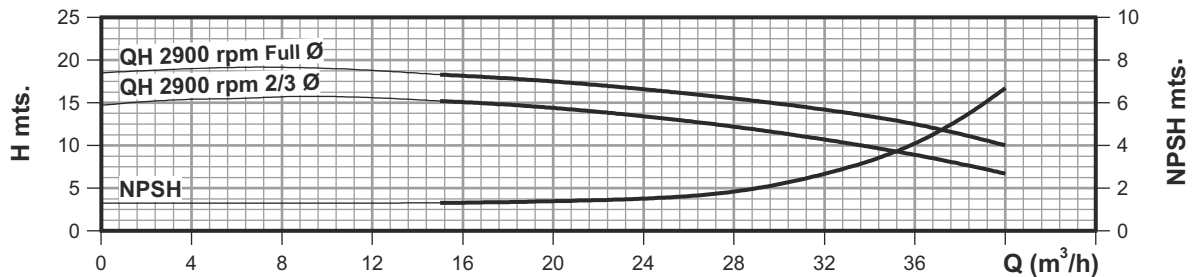
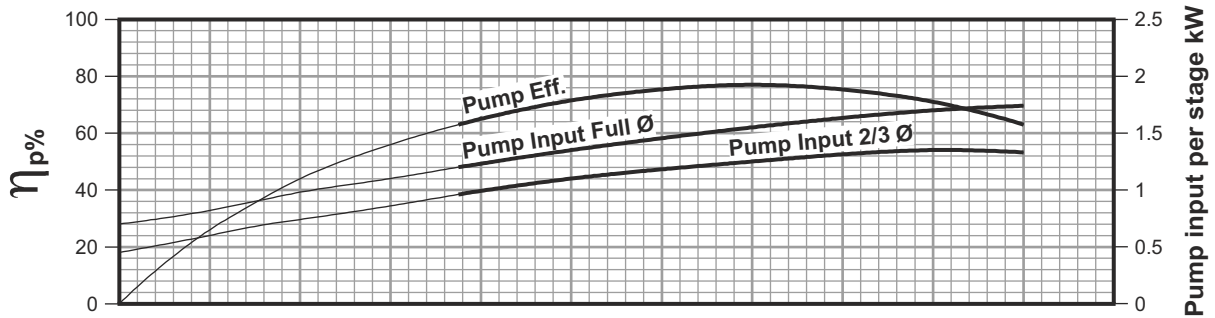
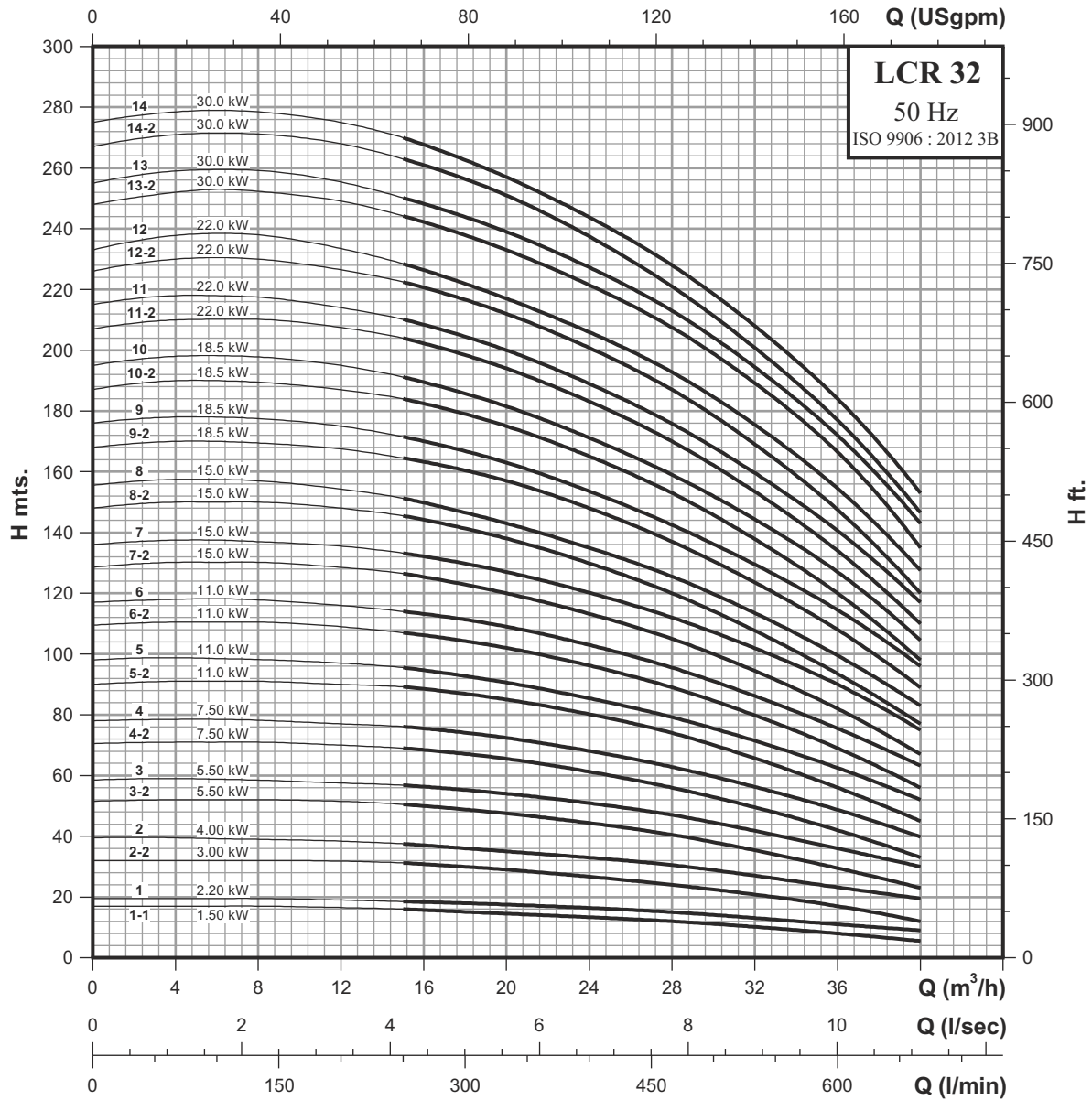

Technical Data

Vertical multistage centrifugal pumps

LCRI, LCRN 32

Performance Chart

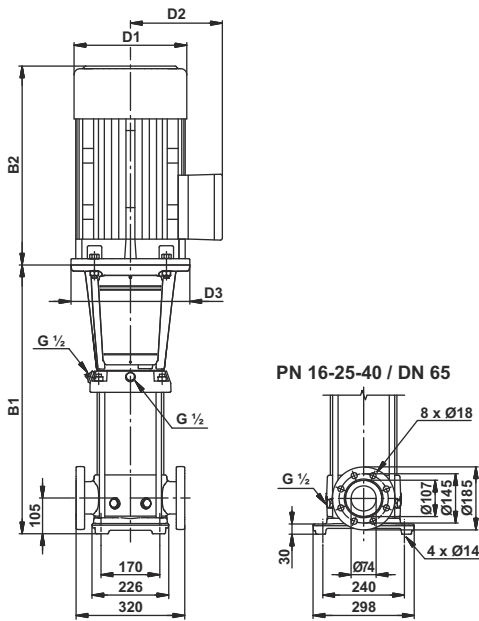

| Pump Type | H.P. | kW | Q l/min m ³ /h | n = 2900 rpm | | | | | |
|--------------------|------|------|---------------------------------|--------------|-------|-------|-------|-------|-------|
| | | | | 250.0 | 333.3 | 400.0 | 466.7 | 533.3 | 600.0 |
| | | | | 15.0 | 20.0 | 24.0 | 28.0 | 32.0 | 36.0 |
| LCRI, LCRN 32/1-1 | 2.00 | 1.50 | H mts. | 16 | 15 | 13 | 12 | 10 | 8 |
| LCRI, LCRN 32/1 | 3.00 | 2.20 | | 19 | 18 | 16 | 15 | 13 | 11 |
| LCRI, LCRN 32/2-2 | 4.00 | 3.00 | | 31 | 29 | 26 | 24 | 21 | 17 |
| LCRI, LCRN 32/2 | 5.50 | 4.00 | | 38 | 35 | 33 | 31 | 27 | 23 |
| LCRI, LCRN 32/3-2 | 7.50 | 5.50 | | 51 | 48 | 44 | 41 | 36 | 30 |
| LCRI, LCRN 32/3 | 7.50 | 5.50 | | 57 | 54 | 51 | 47 | 42 | 36 |
| LCRI, LCRN 32/4-2 | 10.0 | 7.50 | | 69 | 66 | 61 | 56 | 50 | 42 |
| LCRI, LCRN 32/4 | 10.0 | 7.50 | | 76 | 72 | 68 | 63 | 56 | 49 |
| LCRI, LCRN 32/5-2 | 15.0 | 11.0 | | 89 | 85 | 80 | 74 | 66 | 56 |
| LCRI, LCRN 32/5 | 15.0 | 11.0 | | 96 | 91 | 85 | 79 | 72 | 63 |
| LCRI, LCRN 32/6-2 | 15.0 | 11.0 | | 107 | 102 | 96 | 89 | 79 | 69 |
| LCRI, LCRN 32/6 | 15.0 | 11.0 | | 114 | 109 | 103 | 96 | 86 | 76 |
| LCRI, LCRN 32/7-2 | 20.0 | 15.0 | | 127 | 120 | 113 | 105 | 94 | 82 |
| LCRI, LCRN 32/7 | 20.0 | 15.0 | | 133 | 127 | 120 | 112 | 102 | 90 |
| LCRI, LCRN 32/8-2 | 20.0 | 15.0 | | 146 | 138 | 130 | 120 | 108 | 94 |
| LCRI, LCRN 32/8 | 20.0 | 15.0 | | 151 | 143 | 135 | 126 | 113 | 100 |
| LCRI, LCRN 32/9-2 | 25.0 | 18.5 | | 165 | 157 | 148 | 137 | 123 | 108 |
| LCRI, LCRN 32/9 | 25.0 | 18.5 | | 172 | 163 | 153 | 143 | 130 | 115 |
| LCRI, LCRN 32/10-2 | 25.0 | 18.5 | | 184 | 175 | 165 | 153 | 137 | 120 |
| LCRI, LCRN 32/10 | 25.0 | 18.5 | | 191 | 182 | 171 | 159 | 144 | 127 |
| LCRI, LCRN 32/11-2 | 30.0 | 22.0 | | 204 | 194 | 183 | 170 | 153 | 134 |
| LCRI, LCRN 32/11 | 30.0 | 22.0 | | 210 | 200 | 188 | 176 | 159 | 141 |
| LCRI, LCRN 32/12-2 | 30.0 | 22.0 | | 223 | 212 | 200 | 187 | 168 | 148 |
| LCRI, LCRN 32/12 | 30.0 | 22.0 | | 229 | 217 | 206 | 193 | 176 | 155 |
| LCRI, LCRN 32/13-2 | 40.0 | 30.0 | | 244 | 233 | 221 | 208 | 188 | 167 |
| LCRI, LCRN 32/13 | 40.0 | 30.0 | | 250 | 239 | 227 | 213 | 194 | 172 |
| LCRI, LCRN 32/14-2 | 40.0 | 30.0 | | 263 | 251 | 237 | 221 | 200 | 177 |
| LCRI, LCRN 32/14 | 40.0 | 30.0 | 270 | 257 | 244 | 228 | 208 | 184 | |

Dimensions & Weights of LCRI, LCRN Pump

| Pump type | Dimensions [mm] | | | | | Net weight [kg] | Gross weight [kg] | Gross volume [m ³] |
|--------------------|-----------------|-------|-----|-----|-----|-----------------|-------------------|--------------------------------|
| | DIN flange | | D1 | D2 | D3 | | | |
| | B1 | B1+B2 | | | | | | |
| LCRI, LCRN 32/1-1 | 505 | 783 | 165 | 130 | 135 | 61.0 | 119.0 | 0.3745 |
| LCRI, LCRN 32/1 | 505 | 783 | 165 | 130 | 135 | 62.0 | 120.0 | 0.3745 |
| LCRI, LCRN 32/2-2 | 575 | 879 | 194 | 140 | - | 76.0 | 134.0 | 0.3745 |
| LCRI, LCRN 32/2 | 575 | 925 | 220 | 150 | 158 | 87.0 | 145.0 | 0.3745 |
| LCRI, LCRN 32/3-2 | 645 | 1055 | 262 | 177 | 298 | 107.0 | 165.0 | 0.3745 |
| LCRI, LCRN 32/3 | 645 | 1055 | 262 | 177 | 298 | 107.0 | 165.0 | 0.3745 |
| LCRI, LCRN 32/4-2 | 715 | 1125 | 262 | 177 | 298 | 117.0 | 175.0 | 0.3745 |
| LCRI, LCRN 32/4 | 715 | 1125 | 262 | 177 | 298 | 117.0 | 175.0 | 0.3745 |
| LCRI, LCRN 32/5-2 | 895 | 1437 | 304 | 225 | 350 | 155.0 | 225.0 | 0.4495 |
| LCRI, LCRN 32/5 | 895 | 1437 | 304 | 225 | 350 | 155.0 | 225.0 | 0.4495 |
| LCRI, LCRN 32/6-2 | 965 | 1507 | 304 | 225 | 350 | 158.0 | 228.0 | 0.4495 |
| LCRI, LCRN 32/6 | 965 | 1507 | 304 | 225 | 350 | 158.0 | 228.0 | 0.4495 |
| LCRI, LCRN 32/7-2 | 1035 | 1577 | 304 | 225 | 350 | 175.0 | 245.0 | 0.4495 |
| LCRI, LCRN 32/7 | 1035 | 1577 | 304 | 225 | 350 | 175.0 | 245.0 | 0.4495 |
| LCRI, LCRN 32/8-2 | 1105 | 1647 | 304 | 225 | 350 | 178.0 | 248.0 | 0.4495 |
| LCRI, LCRN 32/8 | 1105 | 1647 | 304 | 225 | 350 | 178.0 | 248.0 | 0.4495 |
| LCRI, LCRN 32/9-2 | 1175 | 1717 | 304 | 225 | 350 | 211.0 | 294.0 | 0.5370 |
| LCRI, LCRN 32/9 | 1175 | 1717 | 304 | 225 | 350 | 211.0 | 294.0 | 0.5370 |
| LCRI, LCRN 32/10-2 | 1245 | 1787 | 304 | 225 | 350 | 214.0 | 297.0 | 0.5370 |
| LCRI, LCRN 32/10 | 1245 | 1787 | 304 | 225 | 350 | 214.0 | 297.0 | 0.5370 |
| LCRI, LCRN 32/11-2 | 1315 | 1925 | 363 | 262 | 350 | 250.0 | 333.0 | 0.5370 |
| LCRI, LCRN 32/11 | 1315 | 1925 | 363 | 262 | 350 | 250.0 | 333.0 | 0.5370 |
| LCRI, LCRN 32/12-2 | 1385 | 1995 | 363 | 262 | 350 | 254.0 | 337.0 | 0.5370 |
| LCRI, LCRN 32/12 | 1385 | 1995 | 363 | 262 | 350 | 254.0 | 337.0 | 0.5370 |
| LCRI, LCRN 32/13-2 | 1455 | 2101 | 415 | 300 | 400 | 322.0 | 419.0 | 0.6245 |
| LCRI, LCRN 32/13 | 1455 | 2101 | 415 | 300 | 400 | 322.0 | 419.0 | 0.6245 |
| LCRI, LCRN 32/14-2 | 1525 | 2171 | 415 | 300 | 400 | 325.0 | 422.0 | 0.6245 |
| LCRI, LCRN 32/14 | 1525 | 2171 | 415 | 300 | 400 | 325.0 | 422.0 | 0.6245 |



Performance Curves

Vertical multistage centrifugal pumps

LCRI, LCRN 32

