

# Technical Data

Vertical multistage centrifugal pumps

## LCR 20

Performance Chart

Pump Type	H.P.	kW	Q l/min m <sup>3</sup> /h	n = 2900 rpm					
				233.3	300.0	333.3	366.7	400.0	433.3
				14.0	18.0	20.0	22.0	24.0	26.0
LCR 20/1	1.50	1.10	H mts.	13	12	12	11	10	8
LCR 20/2	3.00	2.20		27	25	24	23	20	18
LCR 20/3	5.50	4.00		41	38	36	34	31	27
LCR 20/4	7.50	5.50		56	52	49	46	42	38
LCR 20/5	7.50	5.50		69	64	60	56	52	46
LCR 20/6	10.0	7.50		83	77	73	69	63	57
LCR 20/7	10.0	7.50		97	90	85	80	74	66
LCR 20/8	15.0	11.0		111	104	98	92	85	76
LCR 20/10	15.0	11.0		138	128	122	114	104	94
LCR 20/12	20.0	15.0		167	155	148	138	128	114
LCR 20/14	20.0	15.0		193	180	171	160	147	133
LCR 20/17	25.0	18.5		236	220	208	196	180	162

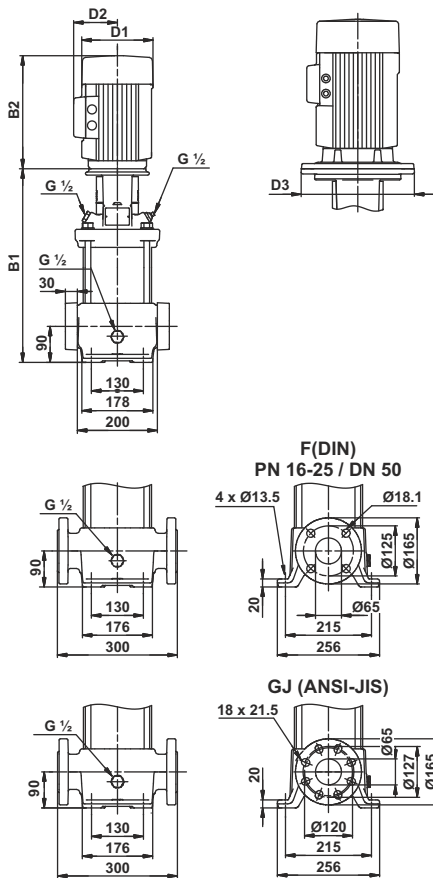

Dimensions & Weights of LCR Pump

Pump type	Dimensions [mm]					Net weight [kg]	Gross weight [kg]	Gross volume [m <sup>3</sup> ]
	DIN flange		D1	D2	D3			
	B1	B1+B2						
LCR 20/1	400	664	160	113	-	42.0	56.0	0.1428
LCR 20/2	415	693	165	130	-	50.0	64.0	0.1428
LCR 20/3	465	815	220	150	-	66.0	92.0	0.2650
LCR 20/4	542	952	262	177	300	88.0	114.0	0.2650
LCR 20/5	587	997	262	177	300	90.0	116.0	0.2650
LCR 20/6	632	1042	262	177	300	93.0	119.0	0.2650
LCR 20/7	677	1087	262	177	300	95.0	124.0	0.2996
LCR 20/8	799	1341	304	225	350	127.0	173.0	0.4671
LCR 20/10	889	1431	304	225	350	130.0	176.0	0.4671
LCR 20/12	979	1521	304	225	350	148.0	201.0	0.5402
LCR 20/14	1069	1611	304	225	350	152.0	205.0	0.5402
LCR 20/17	1204	1746	304	225	350	187.0	240.0	0.5402

# Performance Curves

Vertical multistage centrifugal pumps

LCR 20

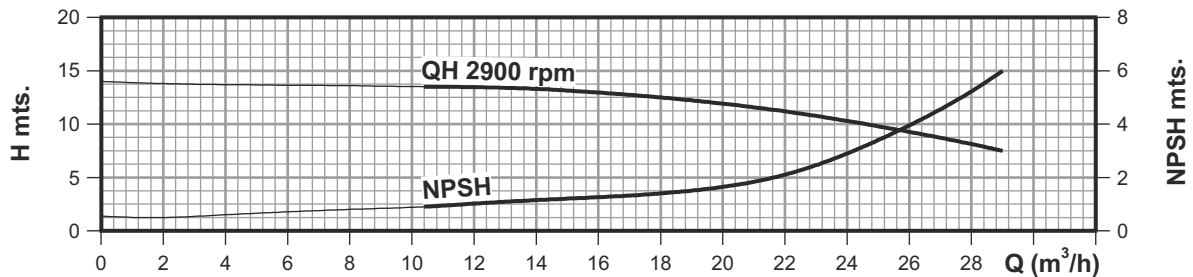
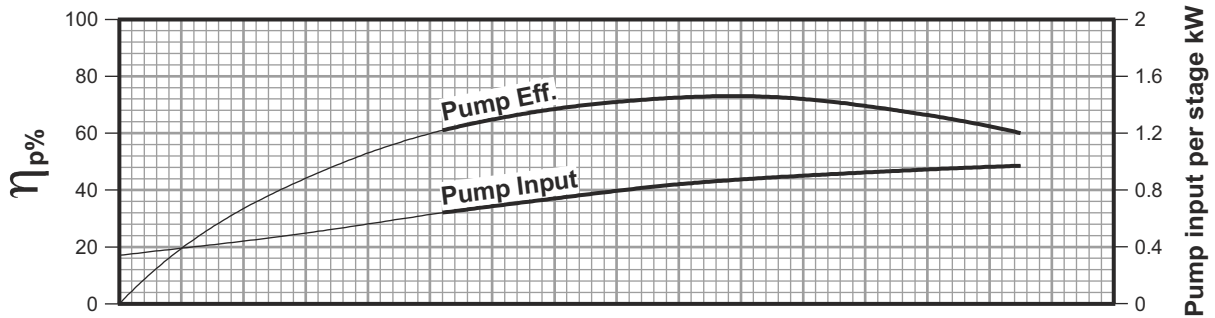
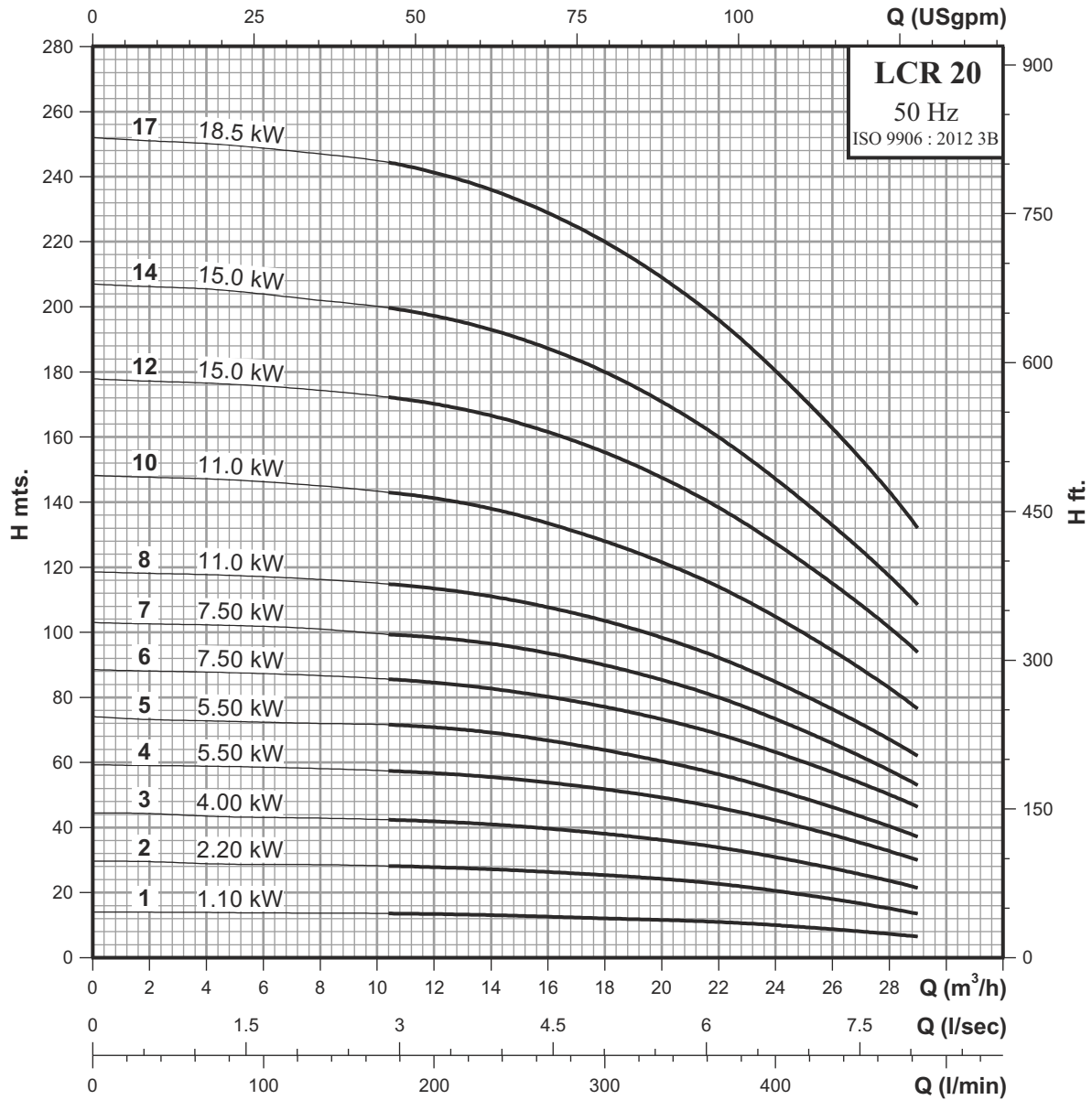

# Technical Data

Vertical multistage centrifugal pumps

## LCRI, LCRN 20

Performance Chart

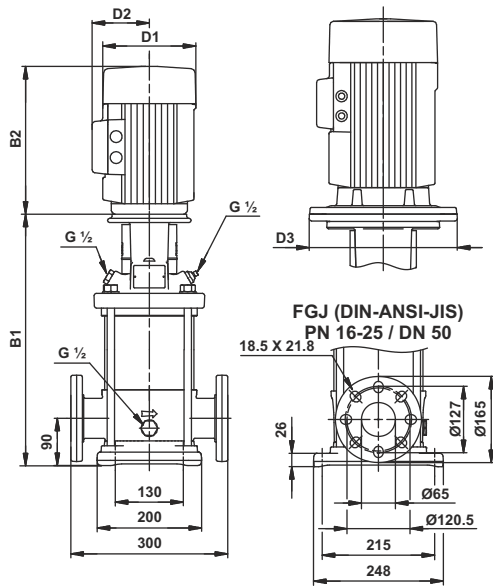

Pump Type	H.P.	kW	Q l/min m <sup>3</sup> /h	n = 2900 rpm					
				233.3	300.0	333.3	366.7	400.0	433.3
				14.0	18.0	20.0	22.0	24.0	26.0
LCRI, LCRN 20/1	1.50	1.10	H mts.	13	12	12	11	10	8
LCRI, LCRN 20/2	3.00	2.20		27	25	24	23	20	18
LCRI, LCRN 20/3	5.50	4.00		41	38	36	34	31	27
LCRI, LCRN 20/4	7.50	5.50		56	52	49	46	42	38
LCRI, LCRN 20/5	7.50	5.50		69	64	60	56	52	46
LCRI, LCRN 20/6	10.0	7.50		83	77	73	69	63	57
LCRI, LCRN 20/7	10.0	7.50		97	90	85	80	74	66
LCRI, LCRN 20/8	15.0	11.0		111	104	98	92	85	76
LCRI, LCRN 20/10	15.0	11.0		138	128	122	114	104	94
LCRI, LCRN 20/12	20.0	15.0		167	155	148	138	128	114
LCRI, LCRN 20/14	20.0	15.0		193	180	171	160	147	133
LCRI, LCRN 20/17	25.0	18.5		236	220	208	196	180	162

Dimensions & Weights of LCRI, LCRN Pump

Pump type	Dimensions [mm]					Net weight [kg]	Gross weight [kg]	Gross volume [m <sup>3</sup> ]
	DIN flange		D1	D2	D3			
	B1	B1+B2						
LCRI, LCRN 20/1	397	661	160	113	-	39.0	53.0	0.1428
LCRI, LCRN 20/2	413	691	165	130	-	47.0	61.0	0.1428
LCRI, LCRN 20/3	463	813	220	150	-	63.0	89.0	0.2650
LCRI, LCRN 20/4	540	950	262	177	300	85.0	111.0	0.2650
LCRI, LCRN 20/5	585	995	262	177	300	87.0	113.0	0.2650
LCRI, LCRN 20/6	630	1040	262	177	300	90.0	116.0	0.2650
LCRI, LCRN 20/7	675	1085	262	177	300	92.0	121.0	0.2996
LCRI, LCRN 20/8	797	1339	304	225	350	123.0	169.0	0.4671
LCRI, LCRN 20/10	887	1429	304	225	350	127.0	173.0	0.4671
LCRI, LCRN 20/12	977	1519	304	225	350	145.0	198.0	0.5402
LCRI, LCRN 20/14	1067	1609	304	225	350	148.0	201.0	0.5402
LCRI, LCRN 20/17	1202	1744	304	225	350	183.0	236.0	0.5402

# Performance Curves

Vertical multistage centrifugal pumps

## LCRI, LCRN 20

