

Technical Data

Vertical multistage centrifugal pumps

LCR 15

Performance Chart

Pump Type	H.P.	kW	Q l/min m ³ /h	n = 2900 rpm					
				233.3	250.0	266.7	300.0	333.3	366.7
				14.0	15.0	16.0	18.0	20.0	22.0
LCR 15/1	1.50	1.10	H mts.	12	12	11	11	10	9
LCR 15/2	3.00	2.20		25	24	23	22	20	18
LCR 15/3	4.00	3.00		37	36	35	32	30	26
LCR 15/4	5.50	4.00		50	48	47	44	39	35
LCR 15/5	5.50	4.00		62	60	59	54	49	44
LCR 15/6	7.50	5.50		74	72	69	65	58	52
LCR 15/7	7.50	5.50		87	84	82	76	70	62
LCR 15/8	10.0	7.50		99	96	93	87	79	70
LCR 15/9	10.0	7.50		112	108	105	98	89	80
LCR 15/10	15.0	11.0		124	121	117	109	99	89
LCR 15/12	15.0	11.0		149	146	140	131	119	106
LCR 15/14	15.0	11.0		174	170	163	152	139	124
LCR 15/17	20.0	15.0		211	206	198	185	169	151

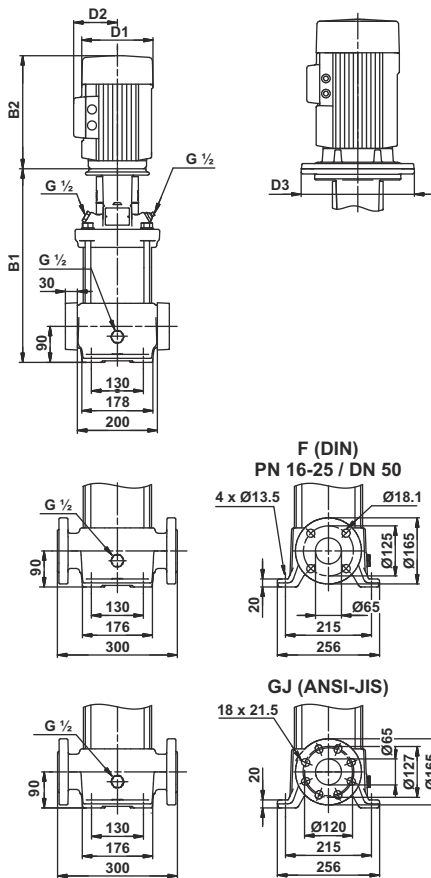

Dimensions & Weights of LCR Pump

Pump type	Dimensions [mm]					Net weight [kg]	Gross weight [kg]	Gross volume [m ³]
	DIN flange		D1	D2	D3			
	B1	B1+B2						
LCR 15/1	400	664	160	113	-	42.0	56.0	0.1428
LCR 15/2	415	693	165	130	-	50.0	64.0	0.1428
LCR 15/3	465	769	194	140	-	55.0	81.0	0.2650
LCR 15/4	510	860	220	150	-	68.0	94.0	0.2650
LCR 15/5	555	905	220	150	-	69.0	95.0	0.2650
LCR 15/6	632	1042	262	177	300	91.0	117.0	0.2650
LCR 15/7	677	1087	262	177	300	93.0	122.0	0.2996
LCR 15/8	722	1132	262	177	300	97.0	126.0	0.2996
LCR 15/9	767	1177	262	177	300	98.0	127.0	0.2996
LCR 15/10	889	1431	304	225	350	130.0	176.0	0.4671
LCR 15/12	979	1521	304	225	350	134.0	187.0	0.5402
LCR 15/14	1069	1611	304	225	350	138.0	191.0	0.5402
LCR 15/17	1204	1746	304	225	350	157.0	210.0	0.5402

Performance Curves

Vertical multistage centrifugal pumps

LCR 15

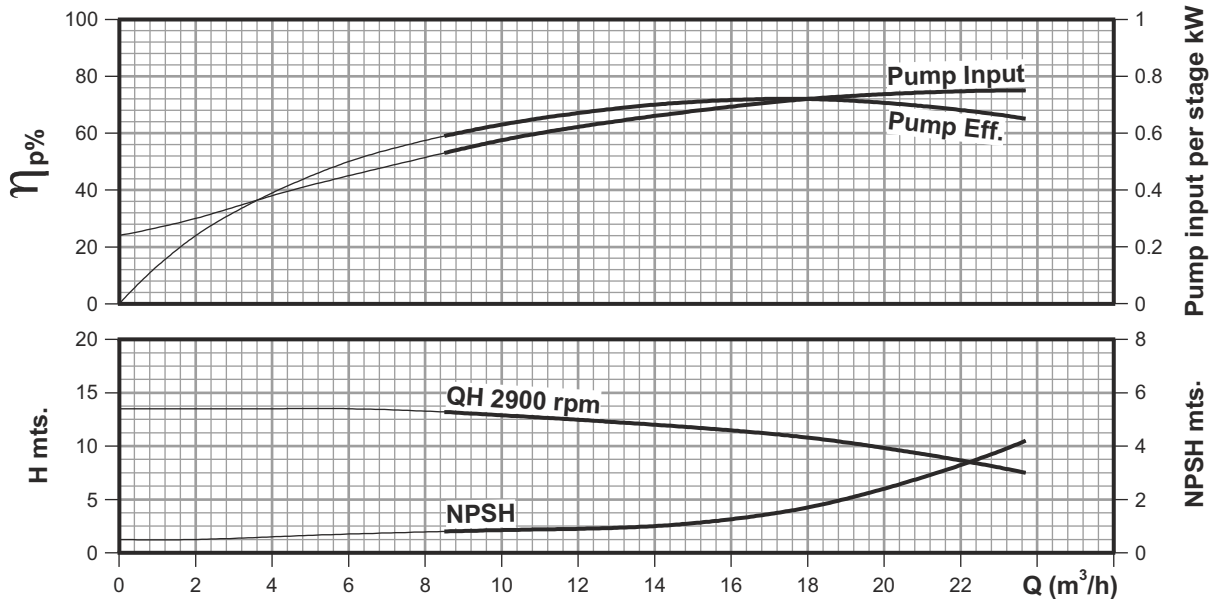
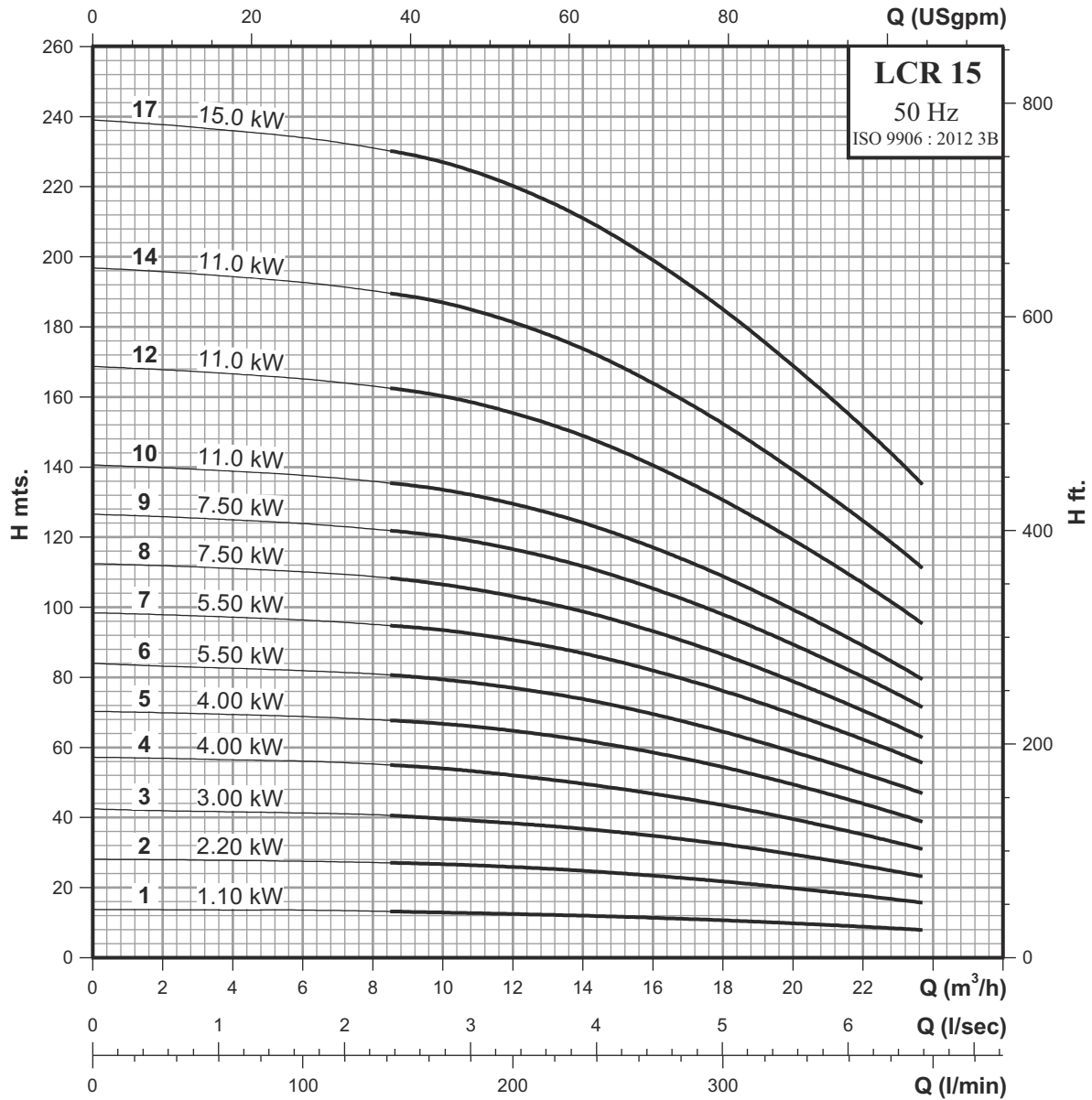

Technical Data

Vertical multistage centrifugal pumps

LCRI, LCRN 15

Performance Chart

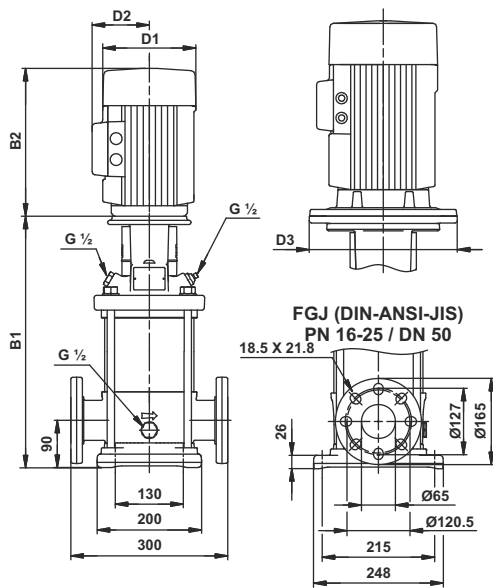

Pump Type	H.P.	kW	Q	n = 2900 rpm						
				l/min	233.3	250.0	266.7	300.0	333.3	366.7
				m ³ /h	14.0	15.0	16.0	18.0	20.0	22.0
LCRI, LCRN 15/1	1.50	1.10	H mts.	12	12	11	11	10	9	
LCRI, LCRN 15/2	3.00	2.20		25	24	23	22	20	18	
LCRI, LCRN 15/3	4.00	3.00		37	36	35	32	30	26	
LCRI, LCRN 15/4	5.50	4.00		50	48	47	44	39	35	
LCRI, LCRN 15/5	5.50	4.00		62	60	59	54	49	44	
LCRI, LCRN 15/6	7.50	5.50		74	72	69	65	58	52	
LCRI, LCRN 15/7	7.50	5.50		87	84	82	76	70	62	
LCRI, LCRN 15/8	10.0	7.50		99	96	93	87	79	70	
LCRI, LCRN 15/9	10.0	7.50		112	108	105	98	89	80	
LCRI, LCRN 15/10	15.0	11.0		124	121	117	109	99	89	
LCRI, LCRN 15/12	15.0	11.0		149	146	140	131	119	106	
LCRI, LCRN 15/14	15.0	11.0		174	170	163	152	139	124	
LCRI, LCRN 15/17	20.0	15.0		211	206	198	185	169	151	
LCRI, LCRN 15/20	25.0	18.5		251	245	238	224	204	180	

Dimensions & Weights of LCRI, LCRN Pump

Pump type	Dimensions [mm]					Net weight [kg]	Gross weight [kg]	Gross volume [m ³]
	DIN flange		D1	D2	D3			
	B1	B1+B2						
LCRI, LCRN 15/1	400	664	160	113	-	42.0	56.0	0.1428
LCRI, LCRN 15/2	415	693	165	130	-	50.0	64.0	0.1428
LCRI, LCRN 15/3	465	769	194	140	-	55.0	81.0	0.2650
LCRI, LCRN 15/4	510	860	220	150	-	68.0	94.0	0.2650
LCRI, LCRN 15/5	555	905	220	150	-	69.0	95.0	0.2650
LCRI, LCRN 15/6	632	1042	262	177	300	91.0	117.0	0.2650
LCRI, LCRN 15/7	677	1087	262	177	300	93.0	122.0	0.2996
LCRI, LCRN 15/8	722	1132	262	177	300	97.0	126.0	0.2996
LCRI, LCRN 15/9	767	1177	262	177	300	98.0	127.0	0.2996
LCRI, LCRN 15/10	889	1431	304	225	350	130.0	176.0	0.4671
LCRI, LCRN 15/12	979	1521	304	225	350	134.0	187.0	0.5402
LCRI, LCRN 15/14	1069	1611	304	225	350	138.0	191.0	0.5402
LCRI, LCRN 15/17	1204	1746	304	225	350	157.0	210.0	0.5402
LCRI, LCRN 15/20*	1339	1881	304	225	350	170.0	220.0	0.5402

Note: * LCRI, LCRN 15/20 pump type is available with PJE coupling only.

Performance Curves

Vertical multistage centrifugal pumps

LCRI, LCRN 15

