

450
PSI

CAUTION: INCORRECT MANIFOLDING WILL CAUSE SEVERE LOCAL STRESS AROUND A PORT AND MAY RESULT IN LEAKS AND PREMATURE FAILURE; TAKE EVERY PRECAUTION LISTED ON PAGE 02, SEE INSTALLATION INSTRUCTIONS FOR FURTHER DETAILS

VIEW AT CENTER SUPPORT
CENTER VESSEL ON 2 OR 3 SUPPORTS
AT SPAN(S) "S": 3 SUPPORTS REQUIRED
FOR LENGTHS 4 AND OVER

DWG REF	QTY	PART NUMBER	DESCRIPTION	MATERIAL
SHELL				
1	1	99281	SHELL	Filament Wound Epoxy/Glass composites - Head locking grooves integrally wound in place.
2	A/R	REF. PAGE 2	F/C Port	CF3M as per SA-351
3	A/R	47135	F/C Port Seal	Ethylene Propylene - Square Cut
4	A/R	45251	F/C Port Retainer	18-8 Stainless Steel
HEAD				
5	2	96803	Bearing Plate	SS316L as per SA-479
6	2	96855	Sealing Plate	Engineering Thermoplastic.
7	2	45317	Head Seal	Ethylene Propylene - O - Ring
8	2	96807	Permeate Port	Engineering Thermoplastic.
9	2	45335	Permeate Port Seal	Ethylene Propylene - O - Ring
10	2	45242	Port Retainer	PH-15-7Mo Stainless Steel
HEAD INTERLOCK				
11	2	45260	Retainer Ring	SS316 as per SA-479
VESSEL SUPPORT				
12	2*	45058	Saddle	Engineering Thermoplastic.
13	2*	47459	Strap Assy.	304 Stainless Steel-PVC Cushion.
14	4**	97821	Strap Screw	5/16-18 UNC x 1.5" Long, 18-8 Stainless Steel
ELEMENT INTERFACE				
15	2	A/R	Adapter	Engineering Thermoplastic.
16	2	45296	Adapter seal	Ethylene Propylene - O - Ring
17	A/R	A/R	PWT seal	Ethylene Propylene - O - Ring

*3 each & **6 nos. furnished with length code 4,5 & 6.

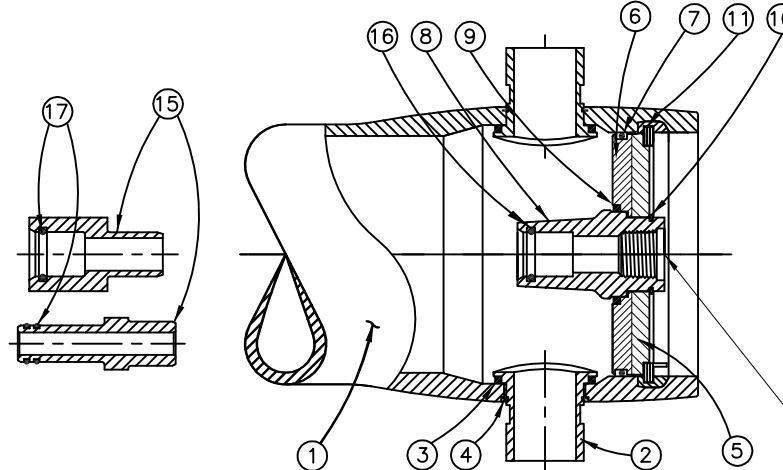

WARNING
INTERNAL PORT PRESSURE NOT TO EXCEED 125 PSI

Dash Length	L IN(MM)	P IN(MM)	S IN(MM)	Approx Weight LB(KG)
-1	48.50 (1232)	42.00 (1067)	25X1 (635)	24 (11)
-2	88.50 (2248)	82.00 (2083)	56X1 (1422)	32 (15)
-3	128.50 (3264)	122.00 (3099)	80X1 (2032)	39 (18)
-4	168.50 (4280)	162.00 (4115)	64X2 (1626)	47 (21)
-5	208.50 (5296)	202.00 (5131)	78X2 (1981)	55 (25)
-6	248.50 (6312)	242.00 (6147)	92X2 (2337)	62 (28)

PENTAIR
CODELINE®

MODEL - 40S45
MEMBRANE HOUSING

DRAWN	MD	ECN	DWG. NO.	REV.
DATE	21APROB	4638	99315	U
CHECKED	MD	DATE	SCALE	SIZE
DATE	21APROB	02JAN18	NONE	P
APPROVED	SS	DATE	SHEET	1 OF 2
DATE	21APROB			



RATING:

DESIGN PRESSURE.....450 PSI
(3.10 Mpa)
MAX. OPERATING TEMP.....120°F
(49°C)
MIN. OPERATING TEMP.....20°F
(-7°C)
FACTORY TEST PRESSURE.....CE/ASME
675 PSIG/495 PSIG
(4.65 MPa)/(3.41 Mpa)
BURST PRESSURE.....2700 PSI
(18.62 MPa)

INTENDED USE:

The Model 40S45 Fiberglass RO/UF Pressure Vessel is designed for continuous, long term use as housing for reverse osmosis and ultrafiltration elements in typical industrial water treatment systems at pressures up to 450 psi. Any make of four-inch nominal diameter spiral-wound element is easily accommodated. The appropriate interfacing hardware for the element specified is furnished with the vessel.

The Model 40S45 is designed in accordance with the engineering standards of the Boiler and Pressure Vessel Code of the American Society of Mechanical Engineers (ASME Code) Section X. At small additional cost, vessels can be inspected during construction by an ASME Authorized inspector and ASME Code stamped.

The Model 40S45 must be installed, operated and maintained in accordance with the listed precautions and good industrial practice to assure safe operation over a long service life.

The high performance reinforced plastic shell must be allowed to expand under pressure; undue restraint at support points or piping connections can cause leaks to develop in the shell. This side ported vessel requires special precautions in mounting and connection to piping so that the vessel will not be subjected to excessive stress due to bending moments acting at the side openings in the fiberglass shell.

The end closures, incorporating close-fitting, interlocking metal components, must be kept dry and free of corrosion; deterioration can lead to catastrophic mechanical failure of the heads.

Pentair will assist the purchaser in determining the suitability of this standard vessel for their specific operating conditions. The final determination however, including evaluation of the standard material of construction for compatibility with the specific corrosive environment, shall be the responsibility of the purchaser. Alternate materials with enhanced corrosion resistance are available on special order.

Specifications are subject to change without notice.

PRECAUTIONS:

- DO...read, understand and follow all instructions; failure to take every precaution will void warranty and may result in vessel failure
- DO...mount the shell on horizontal members at span "S" using compliant vessel supports furnished; shim saddles if required. Tighten hold down straps just snug
- DO...align and center side ports with the manifold header. Correct, causes of misalignment in a row of vessels connected to the same header
- DO...use flexible type IPS grooved-end pipe couplings, at side ports; allow full, 0.125 inch gap between port and piping, and position piping to maximize flexibility of connection
- DO...provide flexibility in, and support for piping manifolds so that vessel can grow in length under pressure without undue restraint; provide additional flexible joints in large pipes leading to manifold header
- DO...provide overpressure protection for vessel set at not more than 105% of design pressure
- DO...inspect end closures regularly; replace components that have deteriorated and correct causes of corrosion.
- DO... Lubricate seals sparingly, using nonpetroleum Based lubricants, i.e. Parker Super O-lube®, Glycerin or suitable silicone based lubricants.
- DO NOT...work on any component until first verifying that pressure is relieved from vessel
- DO NOT... make rigid piping connections to ports or clamp vessel in any way that restricts growth of fiberglass shell under pressure; ΔDIA = 0.01 in. (0.25mm) and ΔL = 0.140 in. (3.5mm) for a length code -6 vessel
- DO NOT... hang piping manifolds from ports or use vessel in any way to support other components.
- DO NOT... operate vessel at pressures and temperatures in excess of its rating
- DO NOT... operate vessel without connecting both Permeate Ports internally to complete set of elements or otherwise plug ports internally so that external piping connection is not subjected to feed pressure
- DO NOT... operate vessel with permeate pressure in excess of 125 psi at 120°F (0.86 MPa @ 49°C).
- DO NOT...tighten Permeate Port connection more than one turn past hand tight
- DO NOT... tolerate leaks or allow end closures to be routinely wetted in any way
- DO NOT...pressurize vessel until double-checking to verify that the Locking Ring is in place and fully seated.
- DO NOT... operate outside the pH range 3-11

CAUTION:
EYE PROTECTION SHOULD BE WORN WHEN REMOVING OR INSTALLING RETAINING RING. KEEP FINGERS CLEAR FROM RETAINING RING WHILE INSTALLING LAST OF TWO TURNS. RING MAY SNAP INTO POSITION POSSIBLY PINCHING FINGERS

ORDERING:

Using the chart below, please check the features you require and fax them with your purchase order to our customer service department for expedited processing. For optional materials and/or features not listed below, please consult factory for pricing and availability.

Please note that we require your membrane brand and model number when ordering. If this information is not initially available, you may provide it at a later date by checking the appropriate box below.

VESSEL LENGTH CODE – please check one

CODELINE MODEL 40S45 □ -1 □ -2 □ -3 □ -4 □ -5 □ -6

MEMBRANE BRAND AND MODEL – please check one and fill in information

- Please supply adapters for the following membrane brand and specific model
Brand _____ Model _____
- Membrane brand and model information is not available, but will be supplied to Pentair on or before the following date ____/____/____

CERTIFICATION – please check one

- Hydro testing at 1.1 times the design pressure.
 - ASME Stamped and National Board Registered.
 - In compliance with the ASME Sec X but not Code Stamped.
- Hydro testing at 1.5 times the design pressure.
 - CE Marked Standard.

EXTERIOR FINISH

- Standard – White high-gloss RAL 9003 polyurethane coating over sanded surface.

FEED PORT CONFIGURATION

- Standard – 1” IPS Grooved End
- Optional – Multi-Ports, Port clocking.

Serial number	Opposite	PERMEATE PORT MATERIAL Standard -PET Option-PVC (120°F maximum) Option-316L Stainless Steel
End	End	
<input type="checkbox"/>	<input type="checkbox"/>	
<input type="checkbox"/>	<input type="checkbox"/>	
<input type="checkbox"/>	<input type="checkbox"/>	PERMEATE PORT CONFIGURATION Standard – ½” NPT Female Optional - ½” BSPT/JISPT Female
<input type="checkbox"/>	<input type="checkbox"/>	

Please fill out your feed port configuration in the space below.
List port location first followed by port size for each choice.
Serial number end □□□□□□□□
Opposite end □□□□□□□□

NOTE: For vessel rating to be at 190°F sealing plate material will be PET.
*For sanitary permeate port option refer drawing 99317.

PORT SIZE CODE	P/N
A ¾” NPT FEMALE	97778
B ¾” BSPT/JISPT FEMALE	-----
C 1” GROOVED END	96057

For complete information on proper use of the vessel
Please refer to 40S series USER’S GUIDE - 96897

NOTE
Spiral Retaining Ring Removal Tool
(50303)recommended to open and close vessel.

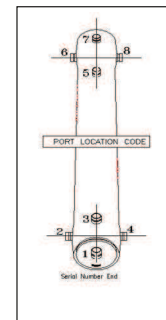

Available with:

FILTRA CONSULTANTS AND ENGINEERS LTD.

Gala No. 2 & 3, Ground Floor, Neminath Industrial Estate No. 2, Navghar, Vasai (East), Dist.: Palghar - 401 219
Tel.: +91 8691009127/26 Email: filtraw@gmail.com Website: www.ewatertreatmentindia.com

