

@dose

THE ALL NEW
BOILER AUTO
DOSING SYSTEMS

 **INITIATIVE**
ENGINEERING

 MADE
IN
INDIA

FILTRA CONSULTANTS AND ENGINEERS LTD.

Gala No. 2 & 3, Ground Floor, Neminath Industrial Estate No. 2, Navghar, Vasai (East), Dist.: Palghar - 401 219
Tel.: +91 8691009127/26 Email: filtraw@gmail.com Website: www.ewatertreatmentindia.com



BOILER FEED WATER CHEMICAL DOSING SYSTEMS

Boiler feed water, chemical need to be dosed and maintained at specific concentration for their desired effects to be achieved.

The object is to optimize the chemical dosing by employing our automatic chemical dosing system **OptiTherm** to achieve the best results.

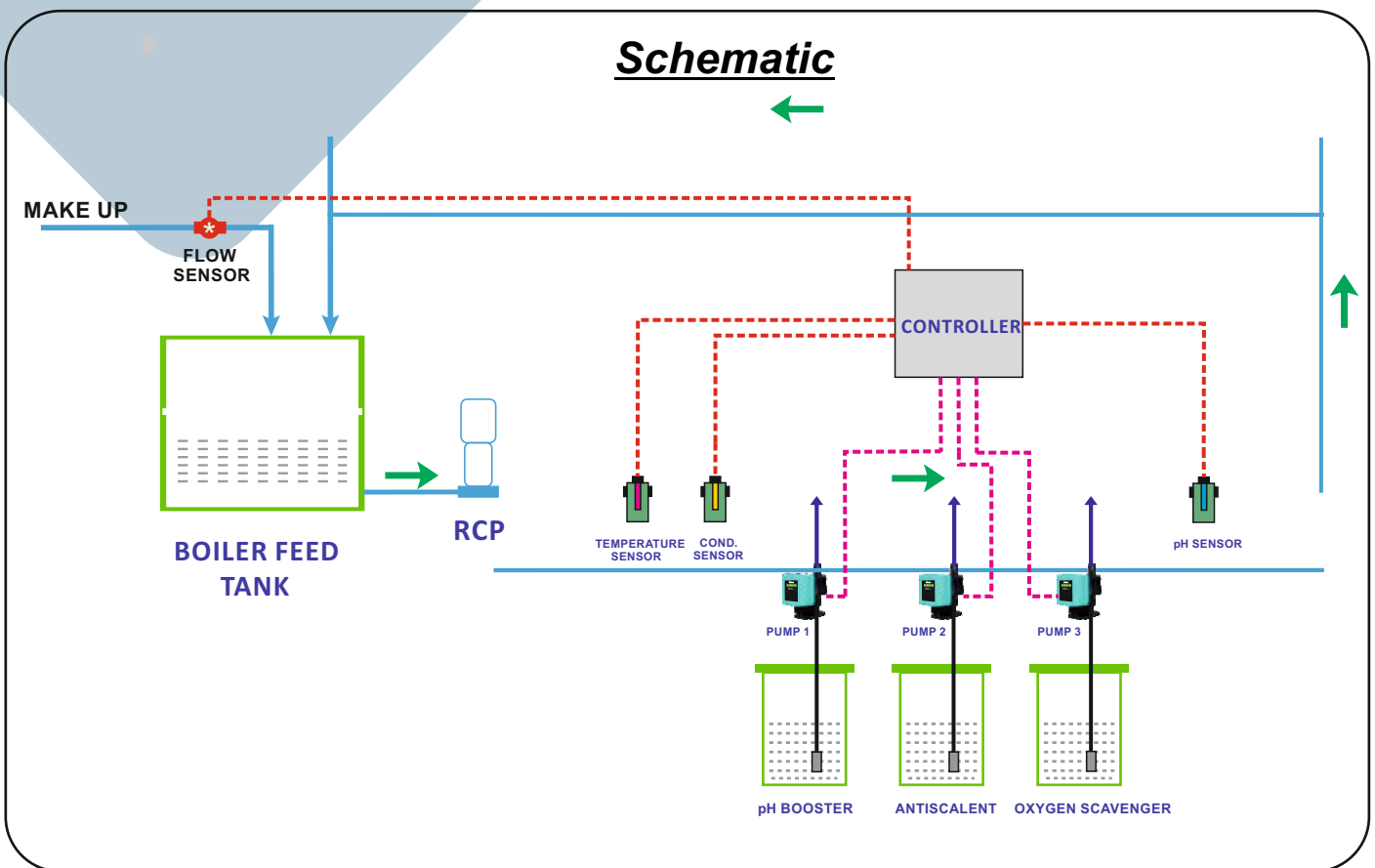

ADVANTAGES OF BOILER CHEMICAL DOSING SYSTEM

- TO PREVENT THE SCALE FORMATION IN THE BOILER AND FEED SYSTEM.
- TO PREVENT CORROSION IN BOILER AND FEED SYSTEM.
- TO MAINTAIN THE BOILER WATER IN ALKALINE CONDITION AND FREE FROM DISSOLVED GASES.
- TO REDUCE CHEMICAL HANDLING AND IMPROVE HEALTH AND SAFETY.

MADE
IN
INDIA

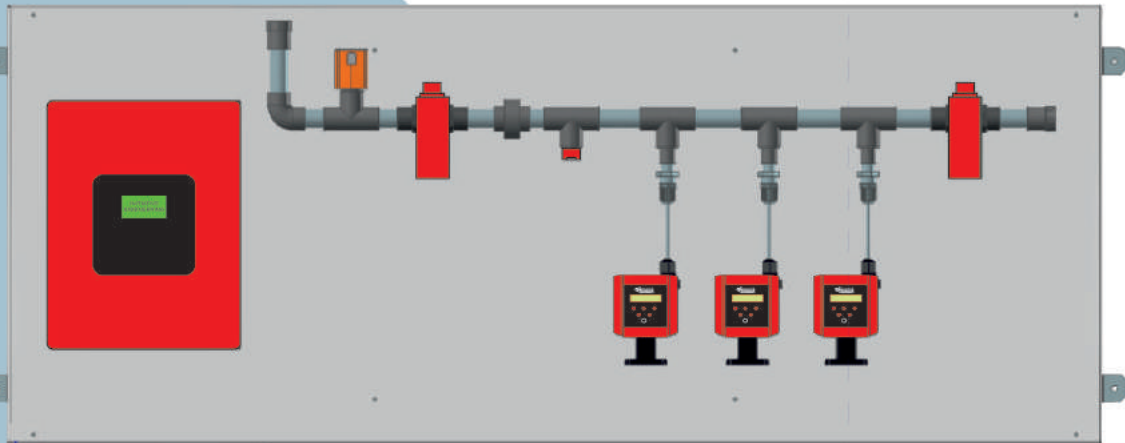

OPTION TO DOSE THREE CHEMICALS



AUTO/MANUAL SELECTION IS AVAILABLE



TEMPERATURE COMPENSATED READINGS FOR pH & CONDUCTIVITY



PROPORTIONAL/FUZZY CONTROL LOGIC FOR pH BOOSTER



DATA LOGGING VIA USB/RS485



TIME PROPORTIONAL DOSING

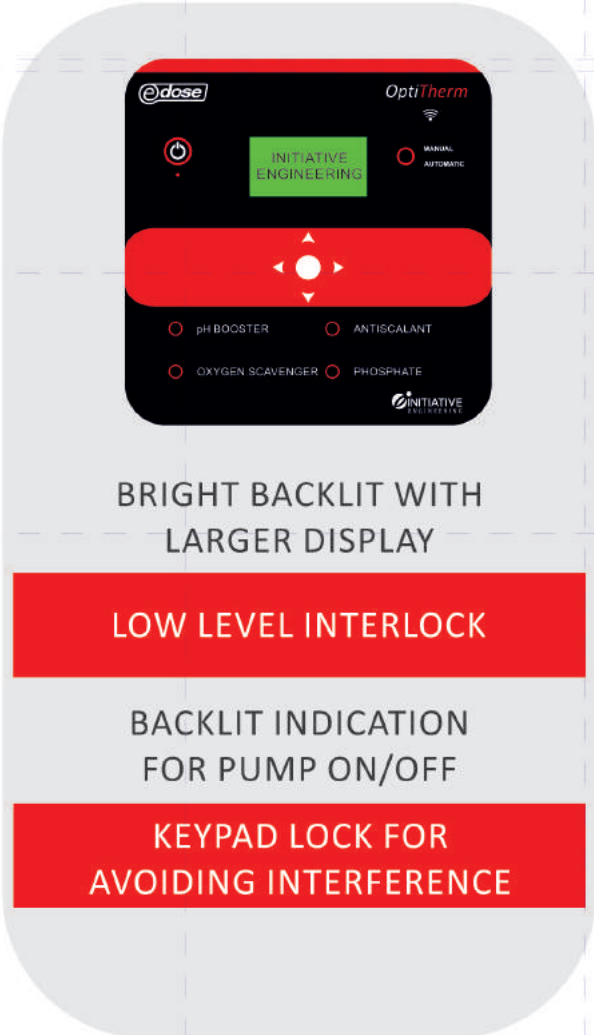

BRIGHT BACKLIT WITH LARGER DISPLAY

LOW LEVEL INTERLOCK

BACKLIT INDICATION FOR PUMP ON/OFF

KEYPAD LOCK FOR AVOIDING INTERFERENCE

DIMENSIONS- 2230L X 820H X 350W



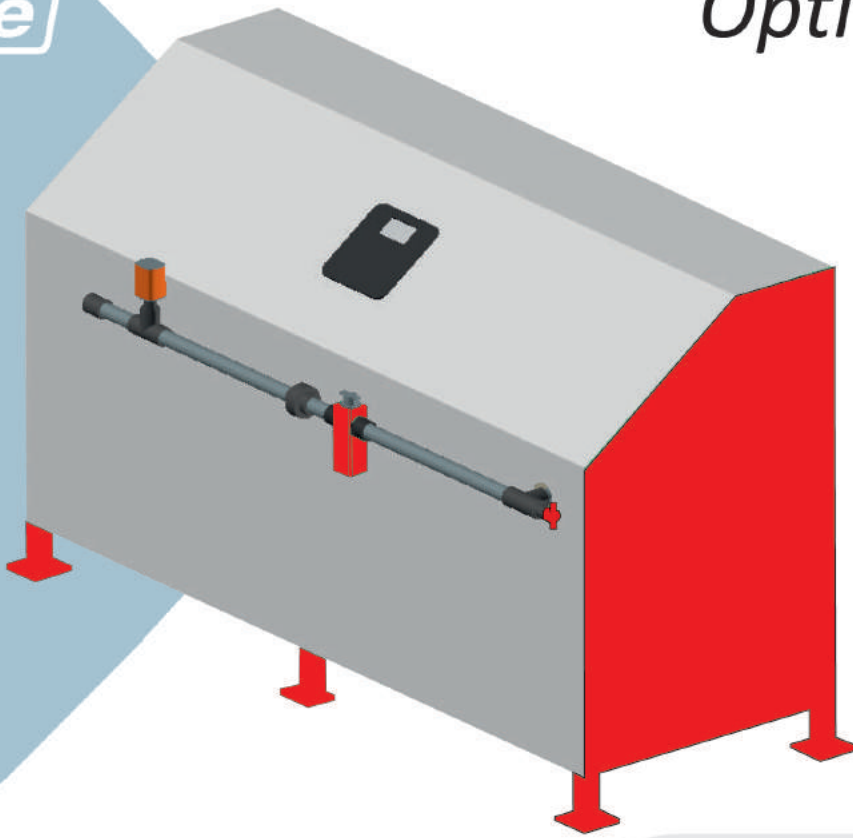

OPTION TO DOSE THREE CHEMICALS



COMPLETE WITH SKID, TANK,
PIPING (PLUG & PLAY)



TIME PROPORTIONAL DOSING



OPTION TO CONNECT DO / FEED
FLOW METER



DAILY, WEEKLY, MONTHLY, YEARLY
CHEMICAL CONSUMPTION DATA
WILL BE LOGGED WITH TIME STAMP



REMOTE MONITORING WITH
CLOUD STORAGE AND DASH BOARD

DIMENSIONS- 2000L X 1350H X 850W mm



COLOR TFT DISPLAY

CAPACITIVE TOUCH PANEL
FOR EASY OPERATION

TRENDING GRAPH FOR EACH
PARAMETER

MIMIC STATUS FOR
COMPLETE OPERATION

MADE
IN
INDIA



LIVE DASHBOARD AND MIMIC

- Dashboard for live status of all parameters.
- MIMIC status of Running operation.

FUNCTION ALARM

- Facility to generate alarm on faulty condition and send notification or alert through email/SMS.
- Facility to export in to Excel sheet.

CHEMICAL CONSUMPTION AND AVAILABILITY

- Available with daily, weekly, monthly, yearly chemical consumption details.
- Chemical storage tanks level monitoring

STREAMLINE MAINTENANCE

- It's of critical importance that all systems, programs and applications are well-maintained and kept up-to-date with overall health checks. Remote monitoring keeps track of the status of all of your technology to ensure that any issues that arise are promptly addressed.

MAINTENANCE ALERT

- having facility to generate maintenance alert for technician through Email.
- Reminder for sensor calibration