

SHELL LENGTH CODE	MODEL	'L' OVER ALL LENGTH MM	'S' SPAN MM	APPROX. ASSEMBLY WEIGHT KG (##)	'P' PORT-PORT MM
1	80-40-SP	1490	676	35	1194
2	80-80-SP	2506	1656	43	2210
3	80-120-SP	3522	2674	51	3226
4	80-160-SP	4539	1845X2	59	4242
5	80-200-SP	5555	2355X2	67	5258
6	80-240-SP	6571	2865X2	75	6274
7	80-280-SP	7587	3300X2	83	7290

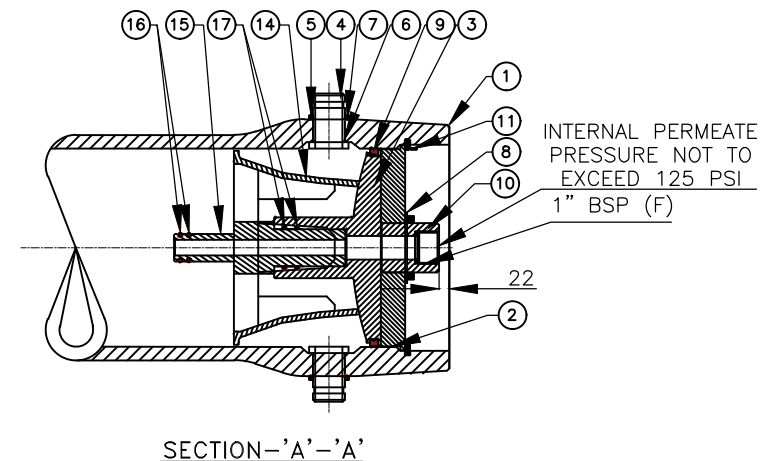

DWG. REF	QTY.	PART NO.	DESCRIPTION	MATERIALS
SHELL				
1	1	---	PRESSURE VESSEL	FILAMENT WOUND EPOXY/GLASS COMPOSITE (HEAD LOCKING GROOVES INTEGRALLY WOUND)
HEAD ASSEMBLY				
2	2	8044	BEARING PLATE	HARD ANODIZED ALUMINUM ALLOY
3	2	8039	SEALING PLATE	ENGINEERING THERMOPLASTIC
4	2	8018	F/C PORT	CF8M
5	2	8019	F/C PORT LOCK NUT	CF8M
6	2	8021	F/C PORT SEAL	EPDM
7	2	8020	F/C PORT WASHER	SS 316
8	2	8014	PORT NUT	ENGINEERING THERMOPLASTIC
9	2	8010	HEAD SEAL	EPDM
10	2	8096	FLAT WASHER	EPDM
END CAP LOCKING				
11	2	8012	RETAINING RING	SS 316
PRESSURE VESSEL SUPPORT				
12	2	**8016	SADDLE	ENGINEERING THERMOPLASTIC
13	2	**8017	STRAP ASSEMBLY	SS 304 WITH CUSHION
MEMBRANE INTERFACE				
14	1	8009	THRUST RING	ENGINEERING THERMOPLASTIC
15	2	8007	ADAPTER	ENGINEERING THERMOPLASTIC
16	4	8094	ADAPTER SEAL - M	EPDM
17	4	8093	ADAPTER SEAL - P	EPDM

WARNING :-
 * INCORRECT / IMPROPERLY SUPPORTED PIPING CAN CAUSE SEVERE STRESS AROUND PORT AND MAY RESULT IN LEAKS AND PREMATURE FAILURE
 * TAKE EVERY PRECAUTION MENTIONED IN USER MANUAL
 * SPECIFICATION SUBJECT TO CHANGE WITHOUT NOTICE

NOTES:
 * NUMBER 14 TO BE USED ONLY AT DOWN STREAM.
 * ADAPTER SPACERS TO BE USED ONLY AT UP STREAM.
 * THIS DRAWING IS FOR REFERENCE PURPOSE, NOT TO BE USED FOR FABRICATION PURPOSE
 * MAX. ANGULAR VARIATION BETWEEN ANY PORTS ±0.5".
 * SHELL EXTERIOR COATED WITH WHITE RAL 9003, HIGH GLOSS POLYURETHANE PAINT.
 * 3 SUPPORTS REQUIRED FOR LENGTH -4 ABOVE.
 * ## WEIGHTS GIVEN IN THE TABLE ARE FOR HIGHEST CONFIGURATION AND WILL VARY WITH CHANGE IN CONFIGURATION.

PORT CONFIGURATION DETAILS	
PORT CONFIG.	VESSEL QUANTITY

REV.	DATE	REVISED BY	DETAILS OF REVISION

TITLE G.A. DRG. OF MEMBRANE HOUSING			
CLIENT M/S.	APPD. YKU	CHD. DKR	DRN. KART
			31.07.18
MODEL : 80-600-SIDE PORT	DRG. No. 80-17-600PSI-SP	DRAWN NOT TO SCALE ALL DIMENSION ARE IN mm	EQ. MARK
			SH. 1 OF 1
			REV 0
			DT. 31.07.



TECHNICAL SPECIFICATION

Design operating pressure 600 PSI (41.37 Bar)
 Max operating temperature 65°C (149° F)
 Min operating temperature -07°C (19.40° F)

Hydro- Test Pressure 660 PSI (45.51 Bar)

USE

UKL fiberglass membrane housing are designed for continuous, long term use as housing for membrane filtration to treat tap & low brackish waters up to 600 PSI. Any standard 8 inch nominal diameter spiral wound or hollow fiber membrane will easily accommodate in UKL membrane housing. The element & head assembly interface hardware for the specified membrane is supplied with the vessel.

Model 80-600PSI has been designed to meet the standards of the American Society of Mechanical Engineer (ASME).

For safer & better service life membrane housing, follow all the given precautionary instructions. Failure to do so will void the warranty.

Quick Checks

- Polyurethane or rubber saddles should be use as an interface between the membrane housing shell & skids/ frame.
- Under pressure, membrane housing must be free to expand. ensure that flexible fittings & couplings are used to allow expansions.
- Vessel must not be subjected to excessive stress caused by bending moments.
- Vessel port & components should not be use to support piping manifold or any other components.

UKL is engaged in continuous development of the product & reserves the right to amend the information given herein without notice & without incurring any obligations.

PRECAUTIONS

Mounting:-

- Mount the membrane housing centered on horizontal members spaced at recommended span (s) using compliant mounting hardware furnished
- Tighten the straps—maximum one ft-lb.

Piping:-

- Use flexible piping/victaulic couplings for permeate & feed/concentrate connections.
- Hanging piping manifolds or supporting other components with membrane housing may result in damaging of membrane housing.
- Permeate port is made of Engineering plastic & tightening the permeate port more than one turn past hand tight will damage the port.

Overpressure Protection:-

- Provide overpressure protection for membrane housing set at not more than 105% design operating pressure.

Inspection:-

- Inspect end closures regularly. replace deteriorated components & correct causes of deterioration.

Servicing:-

- Relive system pressure before working on the membrane housing. Working on system under pressure may result in severe bodily harm or property damage.

Before start-up:-

- Ensure that the retaining ring is in place & fully seated in the groove.

Pressures:-

- Operating the vessel in excess of the ratings, will shorten the life & may result in severe bodily harm or property damage.
- Permeate port are designed to operate at 125 psi operating at pressure in excess of 125 psi must approved by factory.
- Membrane housing are not designed for vacuum conditions operate only in positive pressure applications.

pH Operation:-

- Membrane housing are designed for continuous operation at a pH of 3-11 & for intermittent cleaning pH 2-12 for less than 30 minutes..

STOPPAGE:-

- Some feed waters may cause corrosion under static condition, in order to prevent the system from corrosion, it is recommended to flush the system with permeate water.

ORDERING

While ordering please specific:

- Model
- Element length
- Make & Model of membrane element to be used.
- If any special requirement.

Exterior portion:

- Standard- White high glass polyurethane coat.
- As per customer requirement after getting discussion with factory people.

MODEL IDENTIFICATION

80-600-SP

80	SIZE/INTERNAL DIA. (8")
40	NO OF 40" ELEMENTS(ONE ELEMENT)
600	OPERATING PRESSURE (600 PSI)
SP	TYPE OF ENTRY (SIDE ENTRY)

Spare Material options:

- Please check the table given in drawing no. 80-17-600PSI-SP

PORT CONFIGURATION DETAIL.

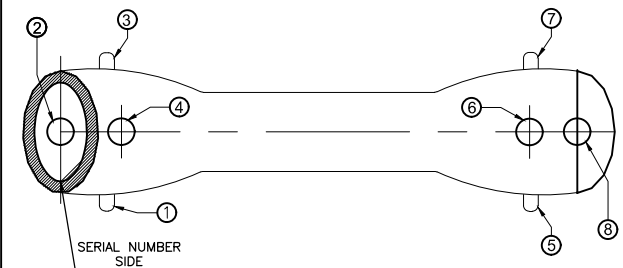

PORT DETAIL

D	1.5" GROOVE DETAIL
E	2" GROOVE DETAIL
F	2.5" GROOVE DETAIL